

| REVISIONS |             |          |          |
|-----------|-------------|----------|----------|
| LTR       | DESCRIPTION | DATE     | APPROVED |
| -         | FIRST ISSUE | 01/20/04 | -        |
| A         |             |          |          |

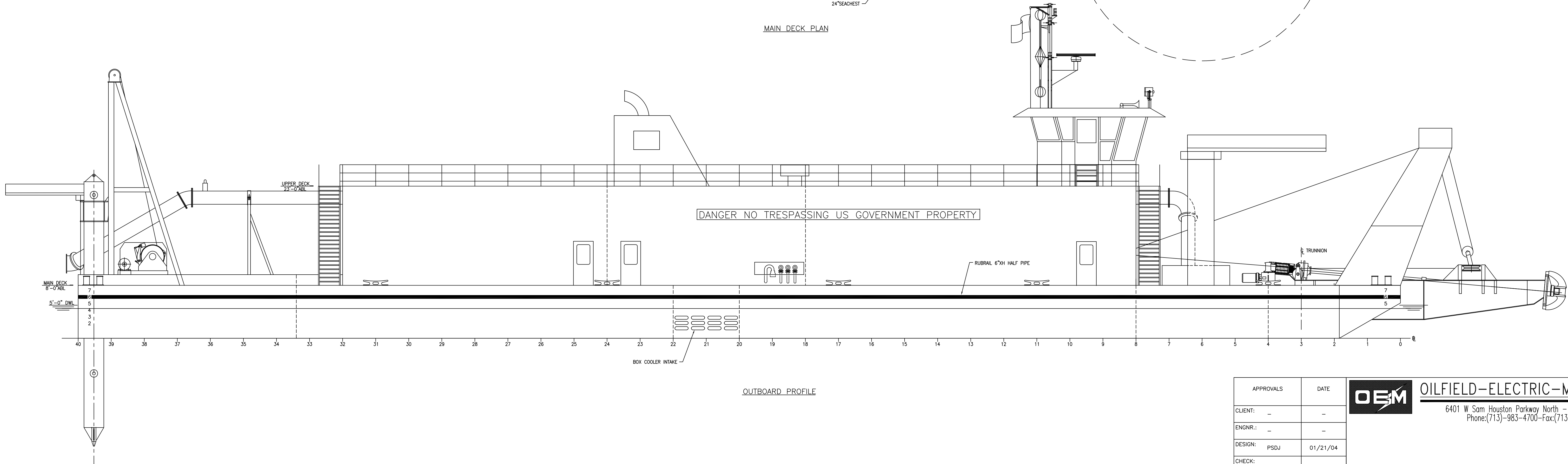
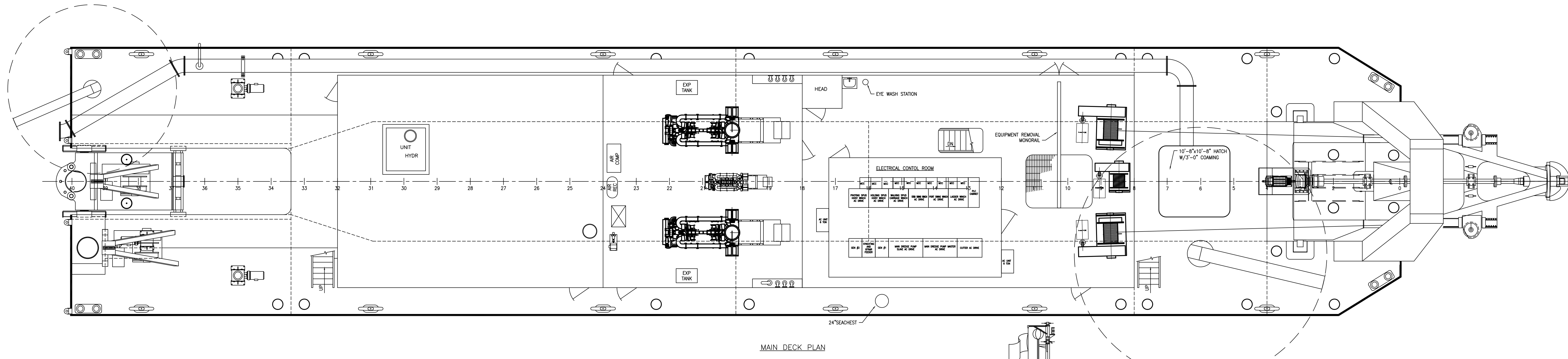
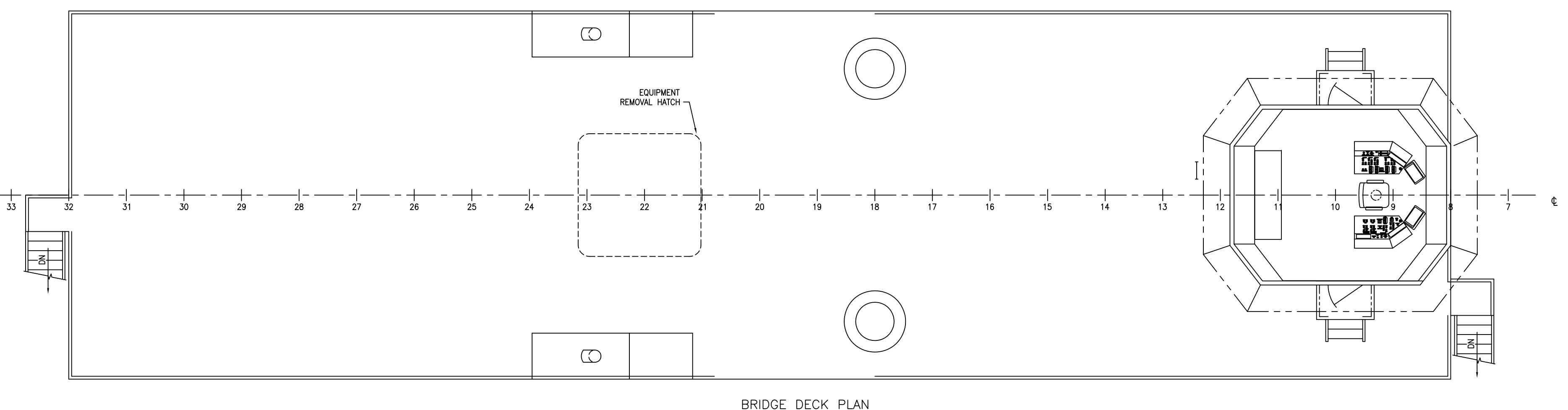
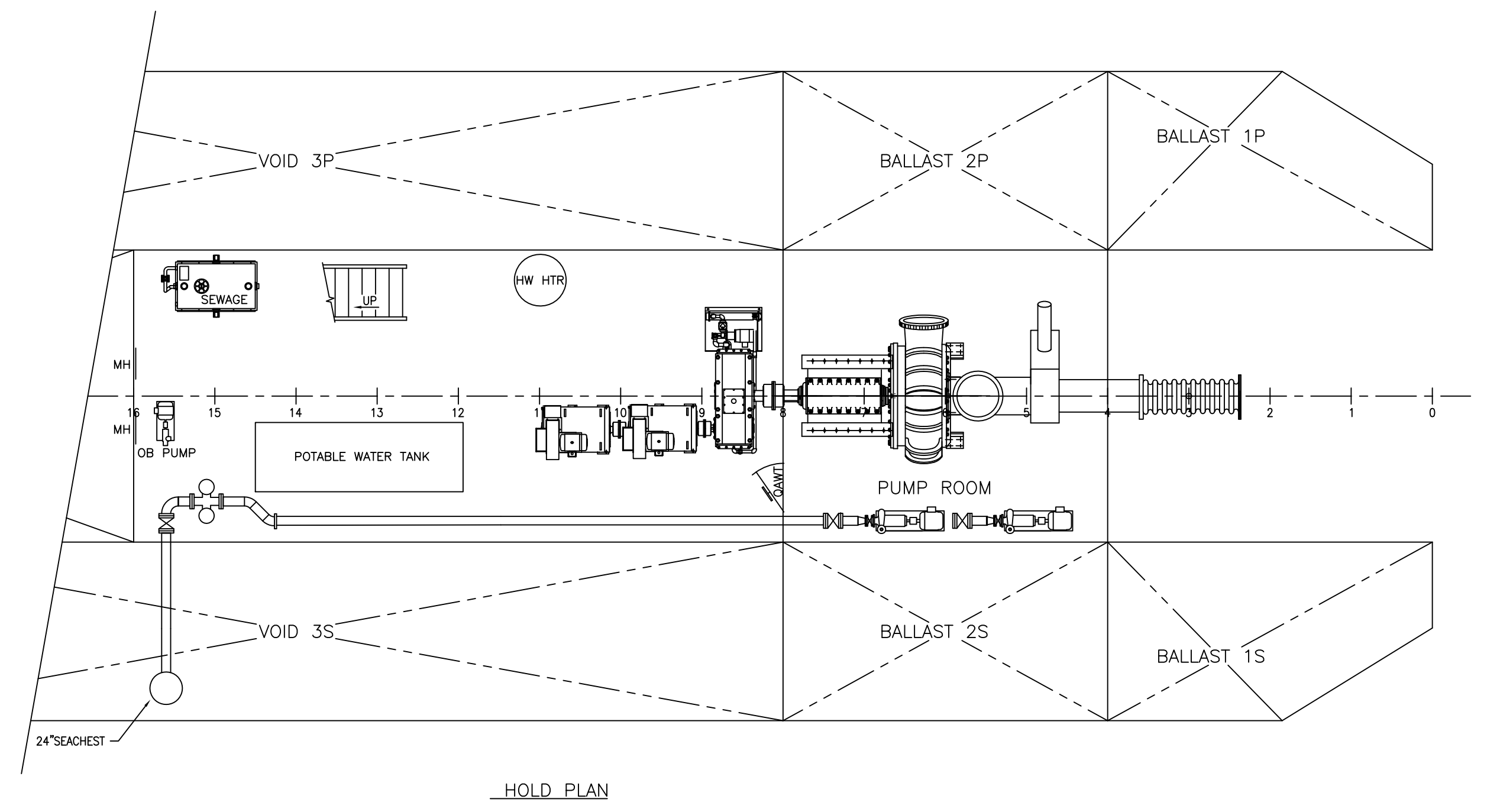
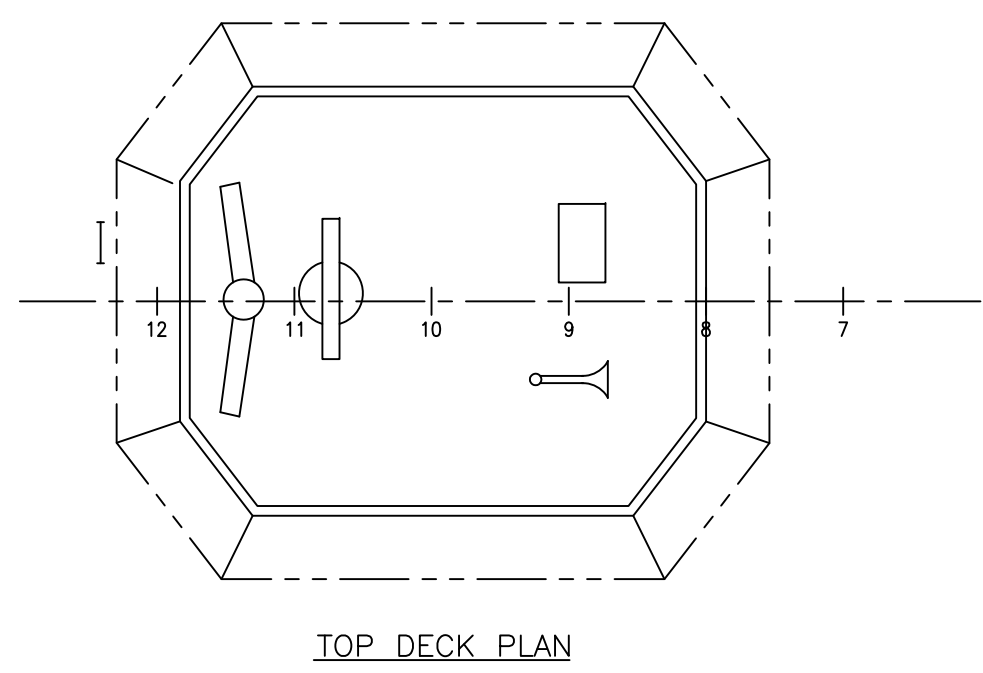

GENERAL CHARACTERISTICS

HULL LENGTH ..... 200'-0"  
 BEAM ..... 40'-0"  
 DEPTH, MIDSHIPS ..... 8'-0"  
 DRAFT, DWL ..... 5'-0"

|              |          |   |  |  |
|--------------|----------|---|--|--|
| APPROVALS    | DATE     | <b>OILFIELD-ELECTRIC-MARINE, INC.</b><br>6401 W Sam Houston Parkway North - Houston TX 77041<br>Phone:(713)-983-4700-Fax:(713)-983-4701 | CUSTOMER/PROJECT                                   | DEPARTMENT OF THE ARMY<br>MARINE DESIGN CENTER<br>CORPS OF ENGINEERS |
| CLIENT: -    | -        |   | DRAWING TITLE                                      | USACE 20" CUTTER SUCTION DREDGE<br>GENERAL ARRANGEMENT & DECK PLANS  |
| ENGR.: -     | -        |   | JOB NO.:   | 659-C215-01  |
| DESIGN: PSDJ | 01/21/04 |   | SCALE:   |  |
| CHECK: -     | -        |   | REV:   |  |
| DRAFT: PSDJ  | 01/21/04 | OEM-STD-E002-00   | COPYRIGHT © 2002<br>OILFIELD-ELECTRIC-MARINE, INC. |  |

8 7 6 5 4 3 2 1

| REVISIONS |             |      |          |
|-----------|-------------|------|----------|
| REV       | DESCRIPTION | DATE | APPROVED |
|           |             |      |          |

**GENERAL CHARACTERISTICS**

|                                 |                  |
|---------------------------------|------------------|
| LENGTH PONTOON                  | 200'-0"          |
| LENGTH O.A.                     | 225'-0"          |
| BREADTH                         | 39'-0"           |
| DEPTH                           | 8'-0"            |
| DRAFT                           | 5'-0"            |
| AIR DRAFT (MAST UP)             | 45'-0"           |
| AIR DRAFT (MAST DOWN)           | 36'-6"           |
| DREDGING DEPTH                  | 28' @ 45 DEGREES |
| SUCTION/DISCHARGE PIPE DIAMETER | 22"/20"          |
| INSTALLED POWER                 | 4010 HP          |

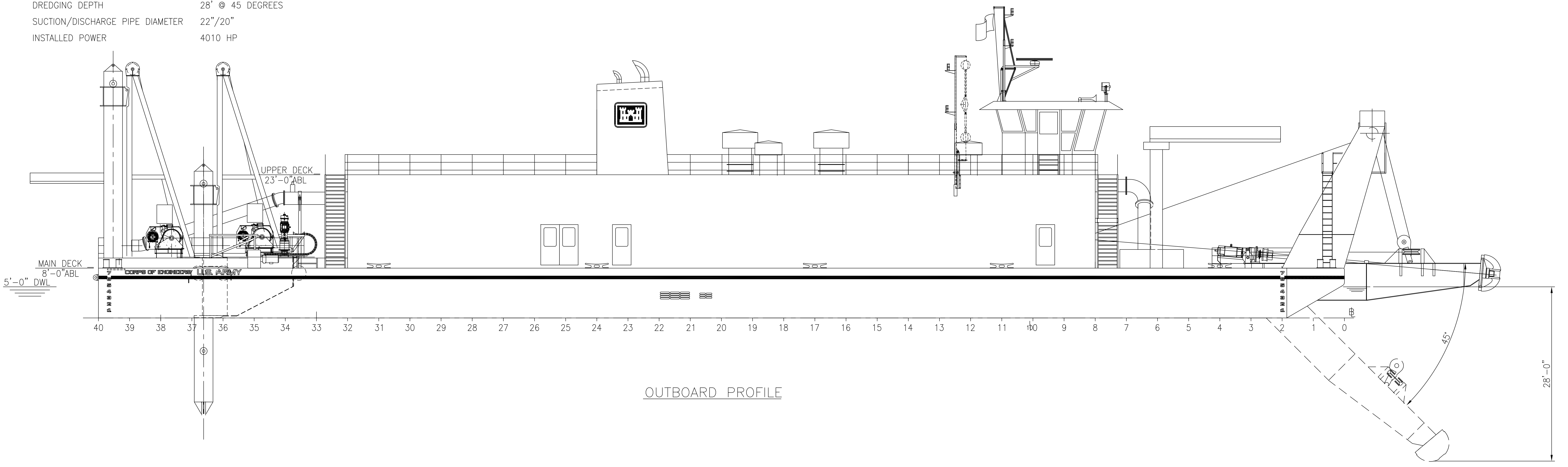

OUTBOARD PROFILE

|  |      |                 |  |
|--|------|-----------------|--|
| <b>OEM OILFIELD-ELECTRIC-MARINE, INC.</b><br>6401 W Sam Houston Pkwy N-Houston, Texas 77041 (713)680-9659-FAX(713)957-1249 |      | SHEET 1 OF 1    |  |
| APPROVALS  |      | DATE            | CUSTOMER/PROJECT   |
| DRAWN  | JIMB | 2/20/04         | DEPARTMENT OF THE ARMY<br>MARINE DESIGN CENTER<br>CORPS OF ENGINEERS |
| CHECKED  |      |                 | DRAWING TITLE 20-INCH CUTTERHEAD SUCTION DREDGE<br>OUTBOARD PROFILE  |
| APPROVED   |      | JOB NO.<br>2457 | DRAWING NO.<br>659-D205-01   |
|  |      |                 | REV.<br>0  |

8 7 6 5 4 3 2 1

GENERAL CHARACTERISTICS

|                                 |                  |
|---------------------------------|------------------|
| LENGTH PONTOON                  | 200'-0"          |
| LENGTH O.A.                     | 225'-0"          |
| BREADTH                         | 39'-0"           |
| DEPTH                           | 8'-0"            |
| DRAFT                           | 5'-0"            |
| AIR DRAFT                       | 45'-0"           |
| DREDGING DEPTH                  | 28' @ 45 DEGREES |
| SUCTION/DISCHARGE PIPE DIAMETER | 22"/20"          |
| INSTALLED POWER                 | 4010 HP          |

| REVISIONS |             |      |          |
|-----------|-------------|------|----------|
| REV       | DESCRIPTION | DATE | APPROVED |
|           |             |      |          |

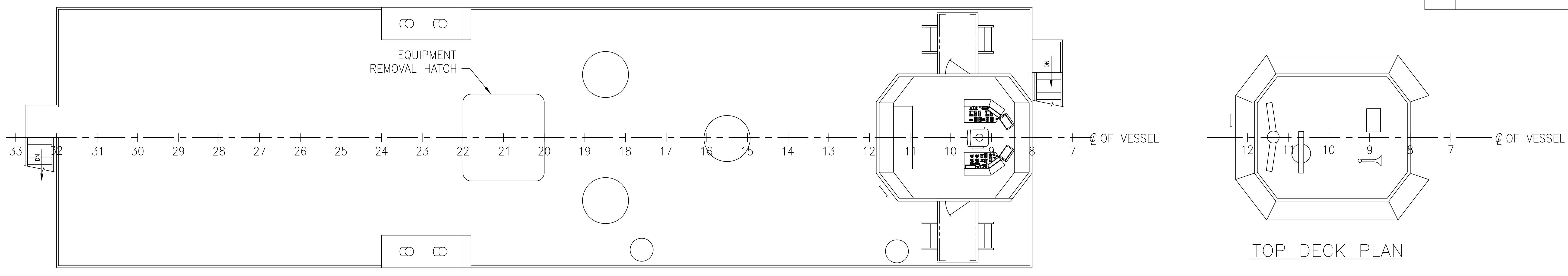

BRIDGE DECK PLAN

TOP DECK PLAN

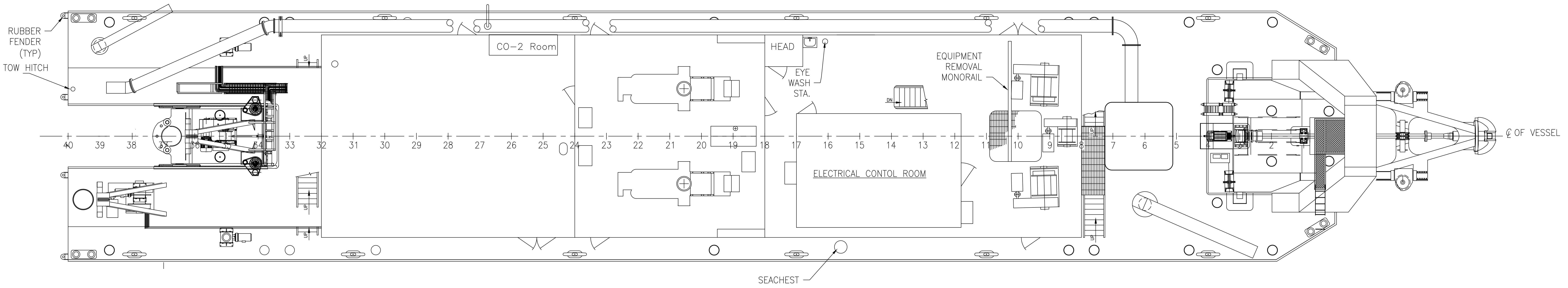

MAIN DECK PLAN

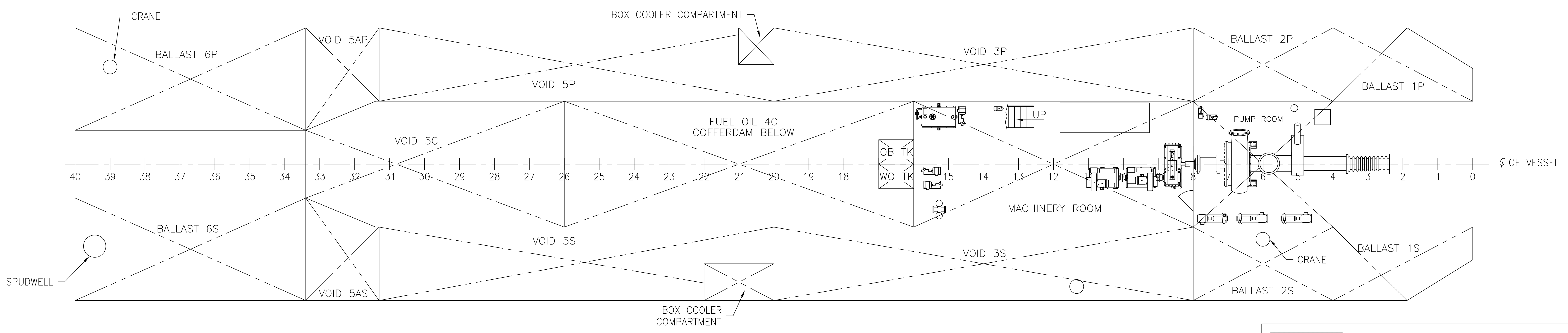

HOLD PLAN

|  |      |              |  |
|--|------|--------------|--|
| <b>OEM</b> OILFIELD-ELECTRIC-MARINE, INC.<br>6401 W Sam Houston Pkwy N-Houston, Texas 77041 (713)680-9659-FAX(713)957-1249 |      | SHEET 1 OF 1 |  |
| APPROVALS  |      | DATE         | CUSTOMER/PROJECT   |
| DRAWN  | JIMB | 2/19/04      | DEPARTMENT OF THE ARMY<br>MARINE DESIGN CENTER<br>CORPS OF ENGINEERS   |
| CHECKED  |      |              | DRAWING TITLE 20-INCH CUTTERHEAD SUCTION DREDGE<br>GENERAL ARRANGEMENT |
| APPROVED   |      |              | JOB NO. 2457 DRAWING NO. 659-D215-01 REV. 0                            |