



**US Army Corps  
of Engineers**  
Philadelphia District

Wanamaker Building  
100 Penn Square East  
Philadelphia, PA 19107-3390  
ATTN: CENAP-OP-R

# Public Notice

---

Public Notice No.  
**CENAP-OP-R-2010-0512**

Date

---

Application No.

File No.

---

In Reply Refer to:  
**REGULATORY BRANCH**

---

This District has received an application for a Department of the Army permit pursuant to Section 10 of the Rivers and Harbors Act of 1899 (33 U.S.C. 403).

The purpose of this notice is to solicit comments and recommendations from the public concerning issuance of a Department of the Army permit for the work described below.

**APPLICANT:** Sean Scarborough  
Scarborough Properties  
415 New Road  
Unit 5  
Somers Point, New Jersey 08244

**AGENT:** Bryon DuBois  
Dubois Environmental Consultants  
249 South Main Street  
Suite 6  
Barnegat, New Jersey 08005

**WATERWAY:** Ship Channel

**LOCATION:** Dredging to occur at Block 1408, Lots 2.01 and 2.04, in the City of Somers Point, Atlantic County, New Jersey/Disposal site would be at Block 793, Lot 15.07, in Lower Township, Cape May County, New Jersey.

**ACTIVITY:** The applicant proposes to remove accumulated sediment from within an existing marina. The marina has been on the site since 1956 and was last dredged in 1990. The excavated material, composed primarily of silts and clay, with some sand, would be removed using an excavator staged on a barge. The material would be loaded onto a hopper barge. This barge would be move to a location adjoining the parking lot. The hopper barge would be empied using a backhoe located on the parking lot and the material would be loaded into dumpsters located on eithers side of the marina. The dumpsters would be surrounded by siltation fencing. The trucks would transport the material to an existing disposal site located along Ocean Drive in Lower Township as shown on the attached map. Approximately nine thousand (9000) cubic yards of material would be removed from approximately four (4) acres of the waterway. The marina would be dredged to a maximum depth of approximately five (5) feet below mean low water.

Equipment proposed to be used at the site would be located no closer than two hundred (200) feet from the centerline of the adjoining waterway. Vessels using the site would have a maximum length of forty six (46) feet with a maximum draft of five (5) feet. The applicant has requested that any permit issued by this office include a provision to allow for maintenance dredging for 10 years.. No fillings of any waters or wetlands are proposed for this project.

**PURPOSE:** The applicant's stated purpose is to provide for safe navigation within the marina for vessels using the site.

A preliminary review of this application indicates that the proposed work would not affect listed species or their critical habitat pursuant to Section 7 of the Endangered Species Act as amended. As the evaluation of this application continues, additional information may become available which could modify this preliminary determination.

The decision whether to issue a permit will be based on an evaluation of the activity's probable impact including its cumulative impacts on the public interest. The decision will reflect the national concern for both protection and utilization of important resources. The benefits which reasonably may be expected to accrue from the work must be balanced against its reasonably foreseeable detriments. All factors which may be relevant to the work will be considered including the cumulative effects thereof; among those are conservation, economics, aesthetics, general environmental concerns, wetlands, cultural values, fish and wildlife values, flood hazards, flood plain values, land use, navigation, shore erosion and accretion, recreation, water supply and conservation, water quality, energy needs, safety, food and fiber production, mineral needs and welfare of the people. A Department of the Army permit will be granted unless the District Engineer determines that it would be contrary to the public interest.

The Corps of Engineers is soliciting comments from the public; Federal, State, and local agencies and officials; Indian Tribes; and other interested parties in order to consider and evaluate the impacts of this proposed activity. Any comments received will be considered by the Corps of Engineers to determine whether to issue, modify, condition or deny a permit for this proposal. To make this decision, comments are used to assess impacts on endangered species, historic properties, water quality, general environmental effects, and the other public interest factors listed above. Comments are used in the preparation of an Environmental Assessment and/or an Environmental Impact Statement pursuant to the National Environmental Policy Act. Comments are also used to determine the need for a public hearing and to determine the overall public interest of the proposed activity.

Comments on the proposed work should be submitted, in writing, within 15 days to the District Engineer, U.S. Army Corps of Engineers, Philadelphia District, Wanamaker Building, 100 Penn Square East, Philadelphia, Pennsylvania 19107-3390.

Review of the National Register of Historic Places indicates that no registered properties or properties listed as eligible for inclusion therein are located within the permit area of the work. Additionally, the permit area has been so extensively modified that little likelihood exists for the proposed project to impact a historic property.

The Magnuson-Stevens Fishery Conservation and Management Act, as amended by the Sustainable Fisheries Act 1996 (Public Law 104-267), requires all Federal agencies to consult

with the National Marine Fisheries Service on all actions, or proposed actions, permitted, funded, or undertaken by the agency that may adversely effect Essential Fish Habitat (EFH). A preliminary assessment of the species listed in the "Guide to Essential Fish Habitat Designations in the Northeastern United States, Volume IV: New Jersey and Delaware", dated March 1999, specifically page 53, any adverse effects on EFH is not substantial. Due to the limited nature of the work, it is the determination of this office that no mitigative measures are warranted in this matter. This office will coordinate with the National Marine Fisheries Service to ensure impacts resulting from the project will be minimal.

In accordance with Section 307(c) of the Coastal Zone Management Act of 1972, applicants for Federal Licenses or Permits to conduct an activity affecting land or water uses in a State's coastal zone must provide certification that the activity complies with the State's Coastal Zone Management Program. The applicant has stated that the proposed activity complies with and will be conducted in a manner that is consistent with the approved State Coastal Zone Management (CZM) Program. No permit will be issued until the State has concurred with the applicant's certification or has waived its right to do so. Comments concerning the impact of the proposed and/or existing activity on the State's coastal zone should be sent to this office, with a copy to the State's Office of Coastal Zone Management.

Compensatory Mitigation: There is no proposed placement of dredged or fill material in waters or wetlands. As such, compensatory mitigation has not been proposed and is not anticipated.

Any person may request, in writing, to the District Engineer, within the comment period specified in this notice, that a public hearing be held to consider this application. Requests for a public hearing shall state in writing, with particularity, the reasons for holding a public hearing.

Additional information concerning this permit application may be obtained by calling Lawrence Slavitter at 215-656-6734, via email at [lawrence.m.slavitter@usace.army.mil](mailto:lawrence.m.slavitter@usace.army.mil), or writing this office at the above address.

Samuel L. Reynolds  
Action Chief, Regulatory Branch

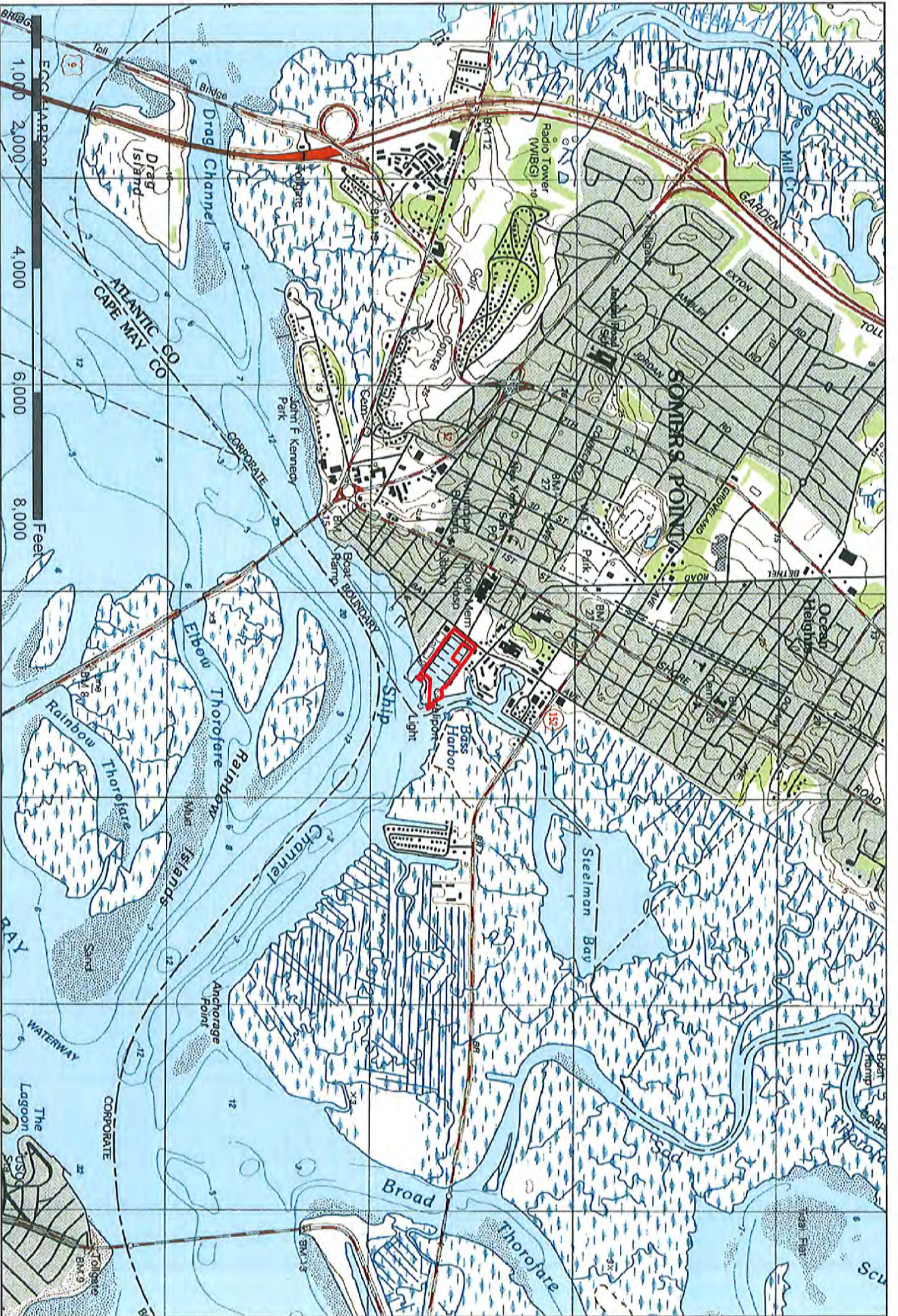

# Ocean City U.S.G.S. Quadrangle Map

Block 1408 \* Lots 2.01 & 2.04  
Somers Point Township, Atlantic County, NJ



Dubois Environmental  
Consultants



NORTH

Sheet No. 1 of 1

Job No.: D1188.002

Scale: 1 in = 2,000 ft

Date: 9/30/2015

Drawn By: AF

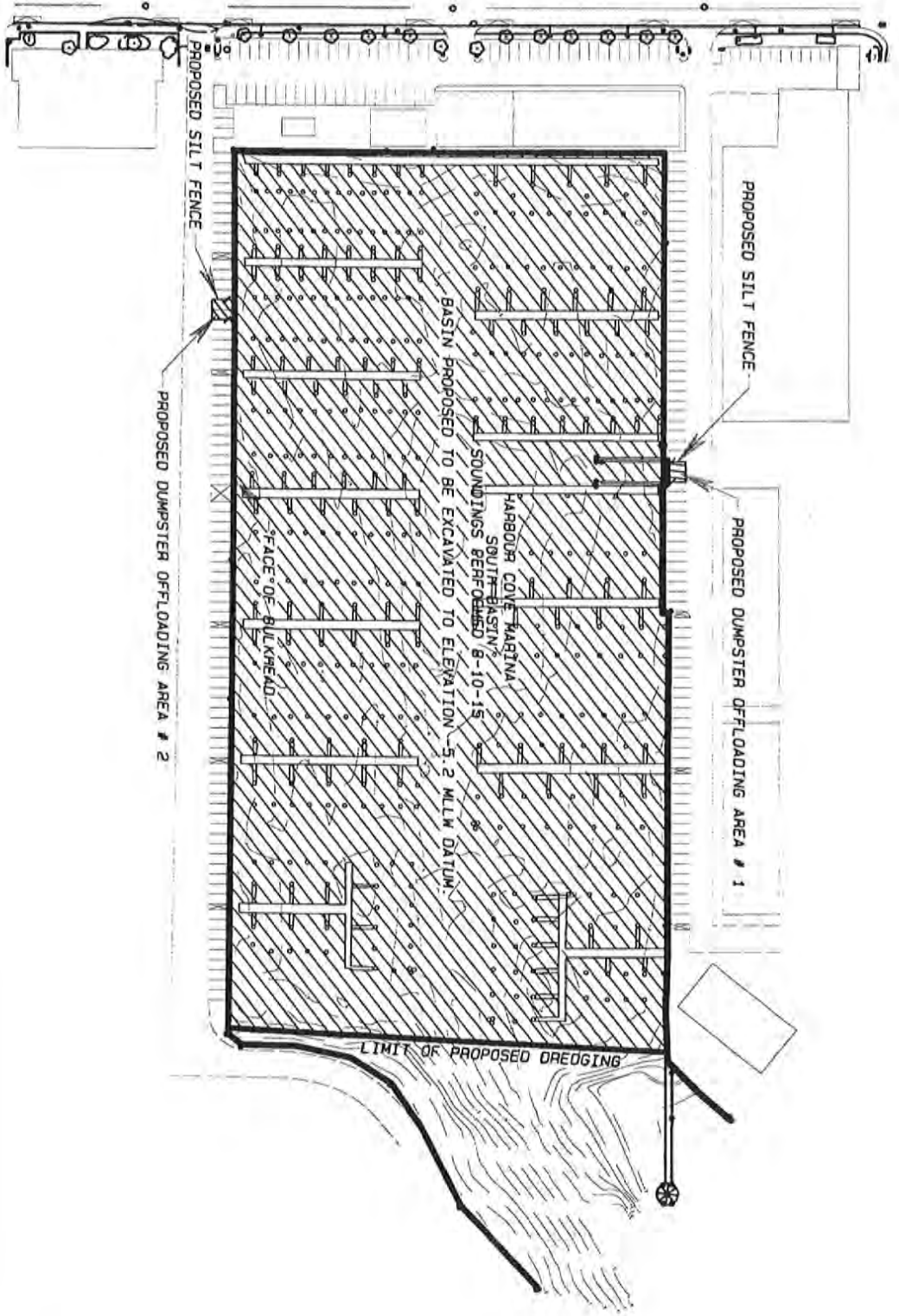

GRAPHIC SCALE 1" = 150'

**Steven Bagge**

Professional Engineer  
N.J. License No. 48197

Date 4-25-16

DREDGING PLAN

HARBOUR COVE SOUTH  
SITUATE  
CITY OF SOMERS POINT  
ATLANTIC COUNTY  
NEW JERSEY

**SPEITEL AND SPEITEL, INC.**

STRATEGIC PLANNERS, CIVIL ENGINEERS, AND ENVIRONMENTAL PERMIT CONSULTANTS  
20 E. TAUNTON ROAD SUITE 304 BORDEN, NEW JERSEY 08008  
609.767.1450

© COPYRIGHT 2016 BY SPEITEL AND SPEITEL, INC. ALL RIGHTS RESERVED. NO PART MAY BE REPRODUCED OR TRANSMITTED IN ANY FORM OR BY ANY MEANS WITHOUT THE WRITTEN PERMISSION OF SPEITEL AND SPEITEL, INC.

NO.	DATE	BY	REVISIONS
1	4-25-16	SB	ISSUE FOR PERMIT
2	3-18-16	SB	REVISED PER PERMIT
3	3-14-16	SB	REVISED PER PERMIT
4	3-2-16	SB	REVISED PER PERMIT

DESIGNER	SB
CONTRACT	1823
DATE	11/2/15
SCALE	1"=150'
REVISOR	4
SHEET	0-1

NO.	DATE	DESCRIPTION
1	3/18/16	ISSUED FOR PERMIT
2		
3		
4		
5		
6		
7		
8		
9		
10		
11		
12		

**SPEITEL AND SPEITEL, INC.**  
 STRATEGIC PLANNERS, CIVIL ENGINEERS, AND ENVIRONMENTAL PERMIT CONSULTANTS  
 200 E. TANTON ROAD SUITE 200 NEW JERSEY CITY, NJ 07310  
 TEL: 201.991.9500 FAX: 201.991.9501  
 WWW.SPEITELANDSPEITEL.COM

HARBOUR COVE SOUTH  
 CITY OF SOMERS POINT  
 ATLANTIC COUNTY  
 NEW JERSEY

DETAIL

CHECKED: [Signature]  
 CONTRACT: 1603  
 DATE: 3/18/16  
 SCALE: NTS  
 REVISION: 1  
 SHEET: D-2

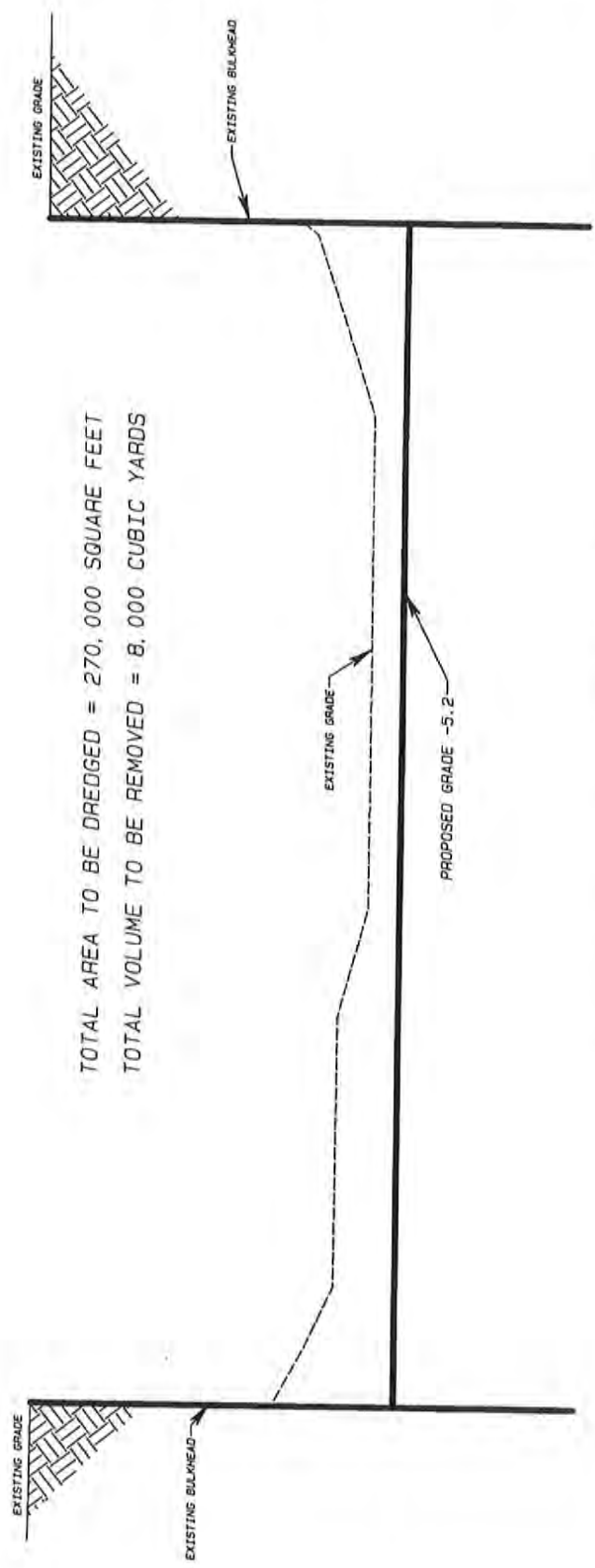

TOTAL AREA TO BE DREDGED = 270,000 SQUARE FEET  
 TOTAL VOLUME TO BE REMOVED = 8,000 CUBIC YARDS

TYPICAL MARINA CROSS SECTION

[Signature]  
**Steven Bagge**  
 Professional Engineer  
 N.J. License No. 48197  
 Date: 3-18-16

NO.	REVISIONS	CHK.
1	MADEP 3/18/16	
2		
3		
4		
5		
6		
7		
8		
9		
10		
11		
12		

**SPEITEL AND SPEITEL, INC.**  
 STRATEGIC PLANNING, CIVIL, ENGINEERS, AND ENVIRONMENTAL PERMIT CONSULTANTS  
 200 E. TANTON ROAD SUITE 504 BERTON, NEW JERSEY 08008  
 609.781.4140  
DESIGNER: JAMES M. SPEITEL, P.E. (NJ License No. 35-260-0001)  
 CHECKER: JAMES M. SPEITEL, P.E. (NJ License No. 35-260-0001)  
 DATE: 3/18/16

HARBOR COVE SOUTH  
 CITY OF SOMERS POINT  
 ATLANTIC COUNTY  
 NEW JERSEY

CONTRACT: 1623  
 DATE: 3/18/16  
 SCALE: NTS  
 REVISIONS: 1  
 SHEET: D-3

  
**Steven Bagge**  
 Professional Engineer  
 N.J. License No. 48197  
 Date: 3-18-16

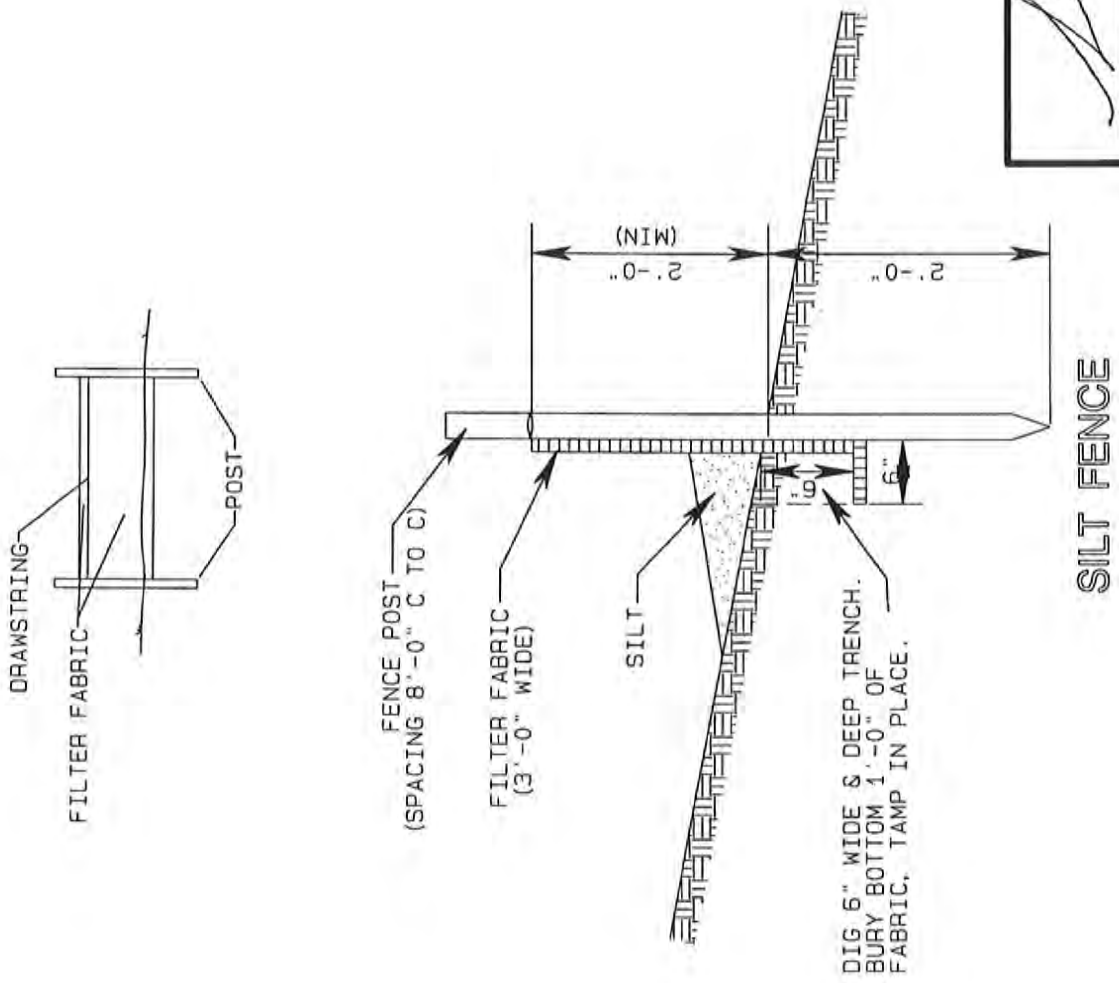

SILT FENCE

CENAP-OP-R-2010-0512



Pleasantville

Cumberland

Maurice River

Dredging Site

Somers Point

Dennis

Sea Isle City

Cape May

Ocean City

Disposal Site

Google Maps

Data SIO, NOAA, U.S. Navy, NGA, GEBCO  
© 2016 Google  
Image Landsat



10 mi