



**US Army Corps  
of Engineers**  
Philadelphia District

Wanamaker Building  
100 Penn Square East  
Philadelphia, PA 19107-3390  
ATTN: CENAP-OP-R

# Public Notice

---

Public Notice No. Date

**CENAP-OP-R-2016-0181-39**

---

Application No. File No.

---

In Reply Refer to:  
**REGULATORY BRANCH**

---

This District has received an application for a Department of the Army permit pursuant to Section 10 of the Rivers and Harbors Act of 1899 (33 U.S.C. 403) and Section 404 of the Clean Water Act (33 U.S.C. 1344).

The purpose of this notice is to solicit comments and recommendations from the public concerning issuance of a Department of the Army permit for the work described below.

**APPLICANT:** Mr. Gary Lewis  
Delaware River Partners, LLC  
1345 Avenues of the Americas  
New York, New York 10105

**AGENT:** Laura George  
Ramboll Environ  
1760 Market Street  
Suite 1000  
Philadelphia, PA 1910

**WATERWAY:** Delaware River

**LOCATION:** Block 8, Lots 2, 3, 4, 4.01 and 4.02, in the Gibbstown Section of Greenwich Township, Gloucester County, New Jersey. The site previously was known as the E.I. du Pont de Nemours & Company Repauno Works.

**ACTIVITY:** The applicant proposes to construct a regional port facility by installing docking structures, performing dredging and installing 6 outfall structures. Steel sheet piles would be installed landward of the existing timber cut-off wall that remains from the previous owner. Approximately 1264 square feet of open water habitat would be filled between the proposed sheet pile and the existing earthen berm. Along the downstream side of the berm, a 140 foot by 200 foot concrete open deck platform would be created and supported by 153 24-inch steel piles. Attached parallel to the earthen berm, a 450 foot long, 43 foot wide ballasted concrete deck would be constructed on 180 24-inch steel piles. On the upstream side of the earthen berm, a 140 foot by 100 foot concrete open deck platform would be constructed on 85-24 inch steel piles. A 44 foot by 15 foot breasting dolphin would be attached to the upstream concrete pier by a 94.6 foot long steel walkway. Also attached to the upstream pier, landward of the breasting dolphin, an 86.25 foot long steel walkway would extend to a concrete pile supported platform; the steel walkway would then extend an additional 77.75 feet and connect to

a 17 foot square mooring dolphin. From this dolphin, an 81.25 foot long steel walkway would extend to a second concrete supported platform; the steel walkway would then extend an additional 81.25 feet to a second 17 foot square mooring dolphins. The piles would be installed using impact hammers staged on barges. The concrete piers would be cast in place or be pre-cast materials. Bollards, fenders, liquid cargo loading equipment, piping, lighting poles would be installed onto the concrete decks to support operations at the proposed facility. Bollards would be installed on the dolphins.

An area approximately 29 acres in size would be dredged to a depth of -40 feet mean lower low water  $\pm$  1 foot overdraft. Approximately 13 acres of the waterway was last dredged in 1992 in association with operations of the previous owner. The material, composed primarily of a silt layer covering sand, would be removed using mechanical and/or hydraulic methods. A closed environmental mechanical bucket would be used primarily to excavate the silt layer from the waterway. The bucket would remain closed over the water while the majority of the water drains from the material. The dredged material would then be placed in a hopper barge and allowed to decant, with the excess water returning to the waterway. If the material meets the New Jersey Department of Environmental Protection's requirements with regard to contaminant levels, the material would then be taken directly to the Whites Basin Confined Disposal Facility (CDF) located in Logan Township, Gloucester County, New Jersey. Any materials that do not meet the state requirements (based on initial testing, approximately 106,000 cubic yards of the material proposed to be dredged appears to be contaminated), the material will be transported to an area along the proposed steel sheet piles for processing. The material would be amended with pozzolan on a barge located in the water at the dredging site or barged to the nearby Weeks Marine Facility in the City of Camden, Camden County, New Jersey. The material would then be dried on-site or at the Camden facility and then deposited on the adjoining uplands. The material would then be loaded onto a truck and transported to an off-site facility(s). The proposed disposal facilities would be at one or all of the following:

Gloucester County Solid Waste Complex in Swedesboro, New Jersey;  
Waste Management Landfill in Morrisville, Pennsylvania;  
Atlantic County Utilities Authority Landfill in Egg Harbor Township, New Jersey;  
SLRD Brownfield Site in Mullica Hill, New Jersey; and/or  
Bethlehem Earth in Bethlehem Pennsylvania

The primarily sandy material would be hydraulically dredged from the site and transferred via pipeline approximately 2 miles south to the Whites Basin Re-handling Facility. The pipeline as shown on the attached drawing, would be marked per US Coast Guard regulations and would be located no nearer than 100 feet from the edge of the Federal navigation channel. A second option would be to load the sandy material via hard digging bucket, onto a barge and transported to either the Whites Basin CDF, or to the Fort Mifflin CDF, located in the City of Philadelphia, Philadelphia County, Pennsylvania. A separate permit would need to be obtained from the US Army Corps of Engineers, Operation Division before any material would be accepted at the Fort Mifflin CDF. For material destined for the Whites Basin facility, the dredged material will be placed directly into bottom-dump barges. These barges would then be transported by tugboat to the Whites Basin and discharged into the Basin in accordance with their operating permits. For material approved by the Corps for the Ft. Mifflin site, the dredged material would be mechanically dredged and placed directly into hopper barges. The hopper scows would then be transported by tugboat across the channel to a hydraulic unloader positioned on a spud barge

located adjacent to the Ft. Mifflin CDF site. There, the material would be hydraulically unloaded from the hopper scows directly into one of the upland CDF cells at Ft. Mifflin. A total of approximately 457,000 cubic yards of material would be removed from the waterway. It is also noted that some of the materials dredged from the Delaware River may be used as fill for the development activities on the site.

Additionally, 6 outfall structures would be installed along the shoreline of the property. These outfalls would convey storm water and treated water from the adjoining property to the river. Approximately 3180 square feet of the waterway, waterward of the high tide line would be impacted by rip rap being placed in the waterway to prevent erosion. Equipment used to perform all of the work would be staged on barges and on land.

Equipment to be used at the site for the proposed construction activities described herein would be located no closer than 350 feet from the edge of the Federal navigation channel.

In addition to the proposed work along the Delaware River described in this public notice, other work is proposed on the subject property that would affect both upland and wetland areas on the former industrial property. However, those other portions of the subject property contain non-tidal waters and wetlands that are not within the regulatory jurisdiction of the U.S. Army Corps of Engineers pursuant to a decision by the U.S. Environmental Protection Agency on March 2, 1994 allowing the New Jersey Department of Environmental Protection to assume Section 404 permit authority for certain waters and wetlands within the State of New Jersey (Section 404(g)(1)). Under the provisions of this assumption by NJDEP, non-tidal tributaries of the Delaware River and their adjacent wetlands are not subject to the Corps of Engineers regulatory jurisdiction.

**PURPOSE:** The applicant's stated purpose is to redevelop a site and create a deep water marine terminal that can accommodate vessels with a maximum length of 870 feet with a maximum of a 40 foot draft.

A preliminary review of this application indicates that the proposed work may impact 2 fish species listed on the Endangered Species List pursuant to Section 7 of the Endangered Species Act as amended. The first would be the Short-nose Sturgeon (Acipenser brevirostrum) and the second would be Atlantic Sturgeon (Acipenser oxyrinchus) and its proposed critical habitat. The applicant has stated that they are planning to perform the work using best management practices by minimizing impact to aquatic resources. This office has determined that with the inclusion of special conditions to any permit issued by this office, the project is not likely to adversely affect any endangered species in the area of the dredging or the work on the structures. As required under Section 7 of the Endangered Species Act, this office will coordinate with the National Marine Fisheries Service to ensure impacts to these species will be minimal.

The decision whether to issue a permit will be based on an evaluation of the activity's probable impact including its cumulative impacts on the public interest. The decision will reflect the national concern for both protection and utilization of important resources. The benefits which reasonably may be expected to accrue from the work must be balanced against its reasonably foreseeable detriments. All factors which may be relevant to the work will be considered including the cumulative effects thereof; among those are conservation, economics, aesthetics, general environmental concerns, wetlands, cultural values, fish and wildlife values, flood

hazards, flood plain values, land use, navigation, shore erosion and accretion, recreation, water supply and conservation, water quality, energy needs, safety, food and fiber production, mineral needs and welfare of the people. A Department of the Army permit will be granted unless the District Engineer determines that it would be contrary to the public interest.

The Corps of Engineers is soliciting comments from the public; Federal, State, and local agencies and officials; Indian Tribes; and other interested parties in order to consider and evaluate the impacts of this proposed activity. Any comments received will be considered by the Corps of Engineers to determine whether to issue, modify, condition or deny a permit for this proposal. To make this decision, comments are used to assess impacts on endangered species, historic properties, water quality, general environmental effects, and the other public interest factors listed above. Comments are used in the preparation of an Environmental Assessment and/or an Environmental Impact Statement pursuant to the National Environmental Policy Act. Comments are also used to determine the need for a public hearing and to determine the overall public interest of the proposed activity.

**Comments on the proposed work should be submitted, in writing, within 30 days** to the District Engineer, U.S. Army Corps of Engineers, Philadelphia District, Wanamaker Building, 100 Penn Square East, Philadelphia, Pennsylvania 19107-3390.

Section 106 of the National Historic Preservation Act of 1966 (NHPA), as amended, requires Federal agencies to take into account the effects of their undertakings on historic properties. An initial review of the Corps' permit area suggests that it is likely to yield resources eligible for inclusion in the National Register of Historic Places. An investigation for the presence of potentially eligible historic properties is being required by this office.

The Magnuson-Stevens Fishery Conservation and Management Act, as amended by the Sustainable Fisheries Act 1996 (Public Law 104-267), requires all Federal agencies to consult with the National Marine Fisheries Service on all actions, or proposed actions, permitted, funded, or undertaken by the agency that may adversely effect on Essential Fish Habitat (EFH). Based on a review of the document entitled "Guide to Essential Fish Habitat Designations in the Northeastern United States, Volume IV: New Jersey and Delaware", dated March 1999, the site is not located in an area designated as EFH. This office will coordinate with the National Marine Fisheries Service to ensure impacts to aquatic resources will be minimal.

Compensatory mitigation: According to Federal regulation located at 33 CFR 325.1(d)(7) and 33 CFR 332.4 (b)(1), applicants wishing to discharge fill material into waters of the U.S. must include a statement on how they have avoided and minimized impacts as well as how they intend to compensate for unavoidable impacts. The applicant has avoided/minimized impacts to the aquatic environment by incorporating engineering/construction procedures into the process that will substantially reduce impacts to aquatic resources. Additionally, the applicant states that the amount of fill in open water has been minimized by designing a portion of the multi-purpose pier as an open deck structure, and by removing existing deteriorated and unnecessary marine structures. Due to the large area and volume of existing structures to be removed, there is an overall decrease in the area and volume of fill in open water compared to previous conditions. Therefore, it is the opinion of the applicant that the new fill is more than offset by the removal of existing structures and fill, no compensatory mitigation is being offered.

In accordance with Section 307(c) of the Coastal Zone Management Act of 1972, applicants for Federal Licenses or Permits to conduct an activity affecting land or water uses in a State's coastal zone must provide certification that the activity complies with the State's Coastal Zone Management Program. The applicant has stated that the proposed activity complies with and will be conducted in a manner that is consistent with the approved State Coastal Zone Management (CZM) Program. No permit will be issued until the State has concurred with the applicant's certification or has waived its right to do so. Comments concerning the impact of the proposed and/or existing activity on the State's coastal zone should be sent to this office, with a copy to the State's Office of Coastal Zone Management. An application has been submitted to the New Jersey Department of Environmental Protection for the necessary State approvals, which would include the required CZM consistency concurrence.

In accordance with Section 401 of the Clean Water Act, a Water Quality Certificate is necessary from the State government in which the work is located. Any comments concerning the work described above which relate to Water Quality considerations should be sent to this office with a copy to the State.

The evaluation of the impact of the work described above on the public interest will include application of the guidelines promulgated by the Administrator, U.S. Environmental Protection Agency, under authority of Section 404(b) of the Clean Water Act.

Any person may request, in writing, to the District Engineer, within the comment period specified in this notice, that a public hearing be held to consider this application. Requests for a public hearing shall state in writing, with particularity, the reasons for holding a public hearing.

Additional information concerning this permit application may be obtained by calling Lawrence Slavitter at 215-656-6734, via email at: [lawrence.m.slavitter@usace.army.mil](mailto:lawrence.m.slavitter@usace.army.mil), or writing this office at the above address.

Edward E. Bonner  
Chief, Regulatory Branch

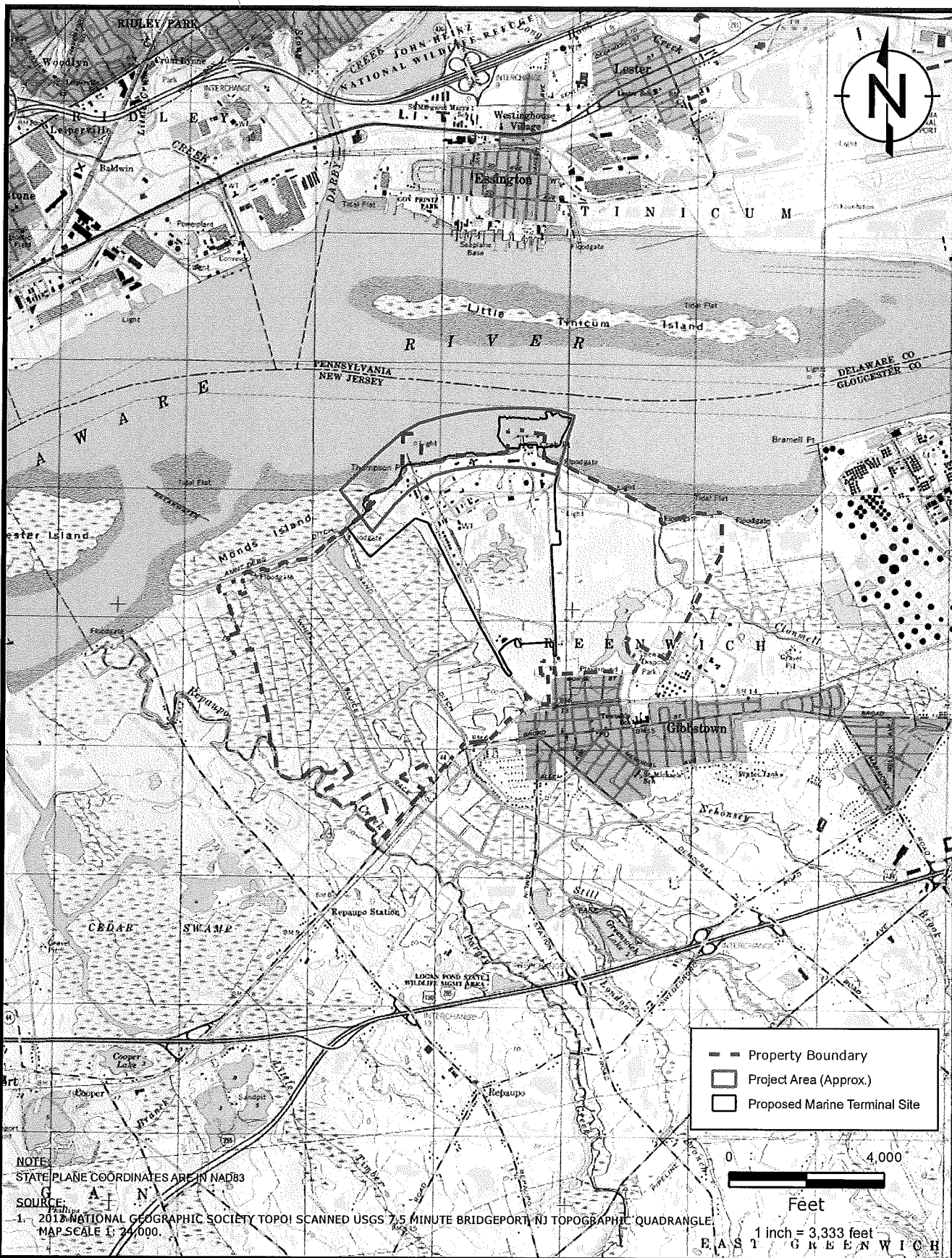

Y:\Projects\Repauno\GIS\XYD\INDEP Permits\1\_SLM\_USACE.mxd

NOTE:  
STATE PLANE COORDINATES ARE IN NAD83  
SOURCE:  
1 - 2011 NATIONAL GEOGRAPHIC SOCIETY TOPOI SCANNED USGS 7.5 MINUTE BRIDGEPORT, NJ TOPOGRAPHIC QUADRANGLE  
MAP SCALE 1:24,000

- Property Boundary
- Project Area (Approx.)
- Proposed Marine Terminal Site

0 4,000  
Feet  
1 inch = 3,333 feet

**RAMBOLL ENVIRON**

DRAFTED BY: HW      DATE: 12/13/2016

**DRP GIBBSTOWN LOGISTICS CENTER  
USGS QUAD MAP  
GIBBSTOWN, NEW JERSEY**

**FIGURE  
1**

02-35702A



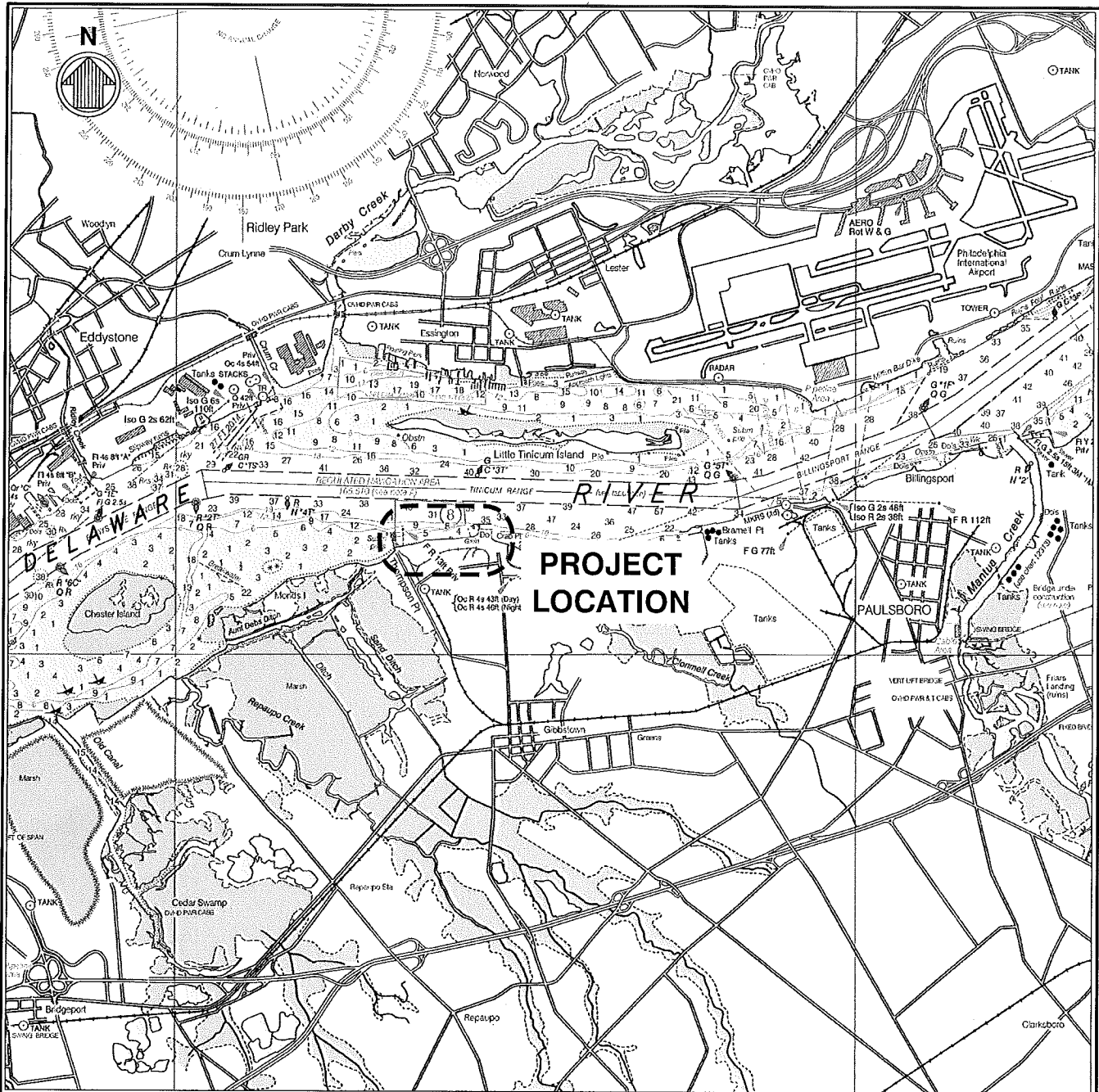

VICINITY MAP

**NOTE:**

BACKGROUND TAKEN FROM NOAA CHART 12312, 56TH ED., MAY 2012.

APPLICATION BY:  
 DELAWARE RIVER PARTNERS, LLC  
 1345 AVENUE OF THE AMERICAS  
 46TH FLOOR  
 NEW YORK, NEW YORK 10105

ENGINEER:  
 **moffatt & nichol**

DRP GIBBSTOWN  
 LOGISTICS CENTER

PROJECT LOCATION:  
 DELAWARE RIVER  
 GIBBSTOWN, GREENWICH TOWNSHIP, NEW JERSEY

2500' 0' 5000' 5000'  
 SCALE: 1"=5000'

DATE: AUGUST 18, 2016  
 REISSUED: JANUARY 3, 2017  
 SHEET 01 OF 31

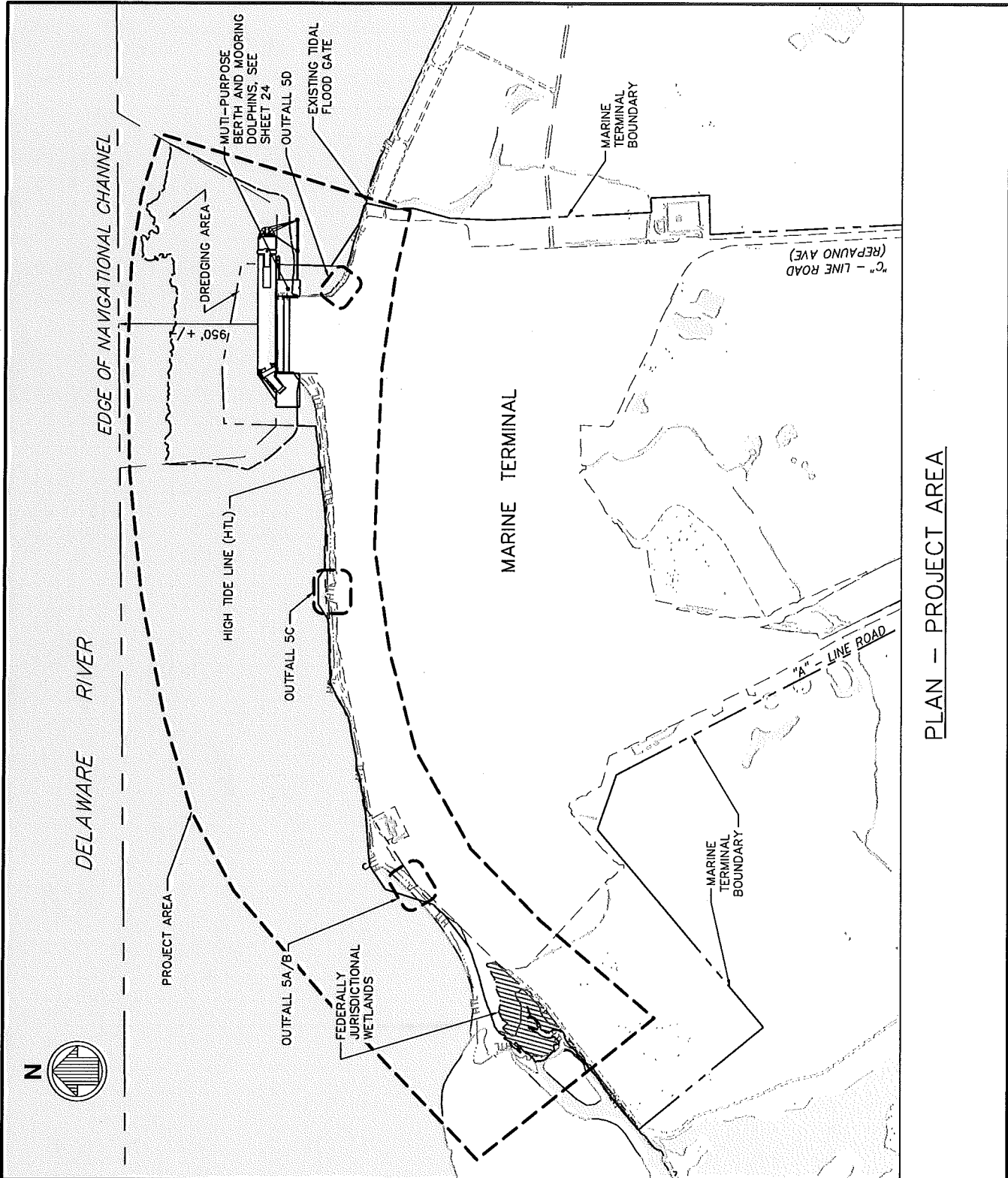

PLAN - PROJECT AREA

APPLICATION BY:  
 DELAWARE RIVER PARTNERS, LLC  
 1345 AVENUE OF THE AMERICAS  
 46TH FLOOR  
 NEW YORK, NEW YORK 10105

ENGINEER:  
 **moffatt & nichol**

DRP GIBBSTOWN  
 LOGISTICS CENTER

PROJECT LOCATION:  
 DELAWARE RIVER  
 GIBBSTOWN, GREENWICH TOWNSHIP, NEW JERSEY

400' 0' 400' 800'  
 SCALE: 1"=800'



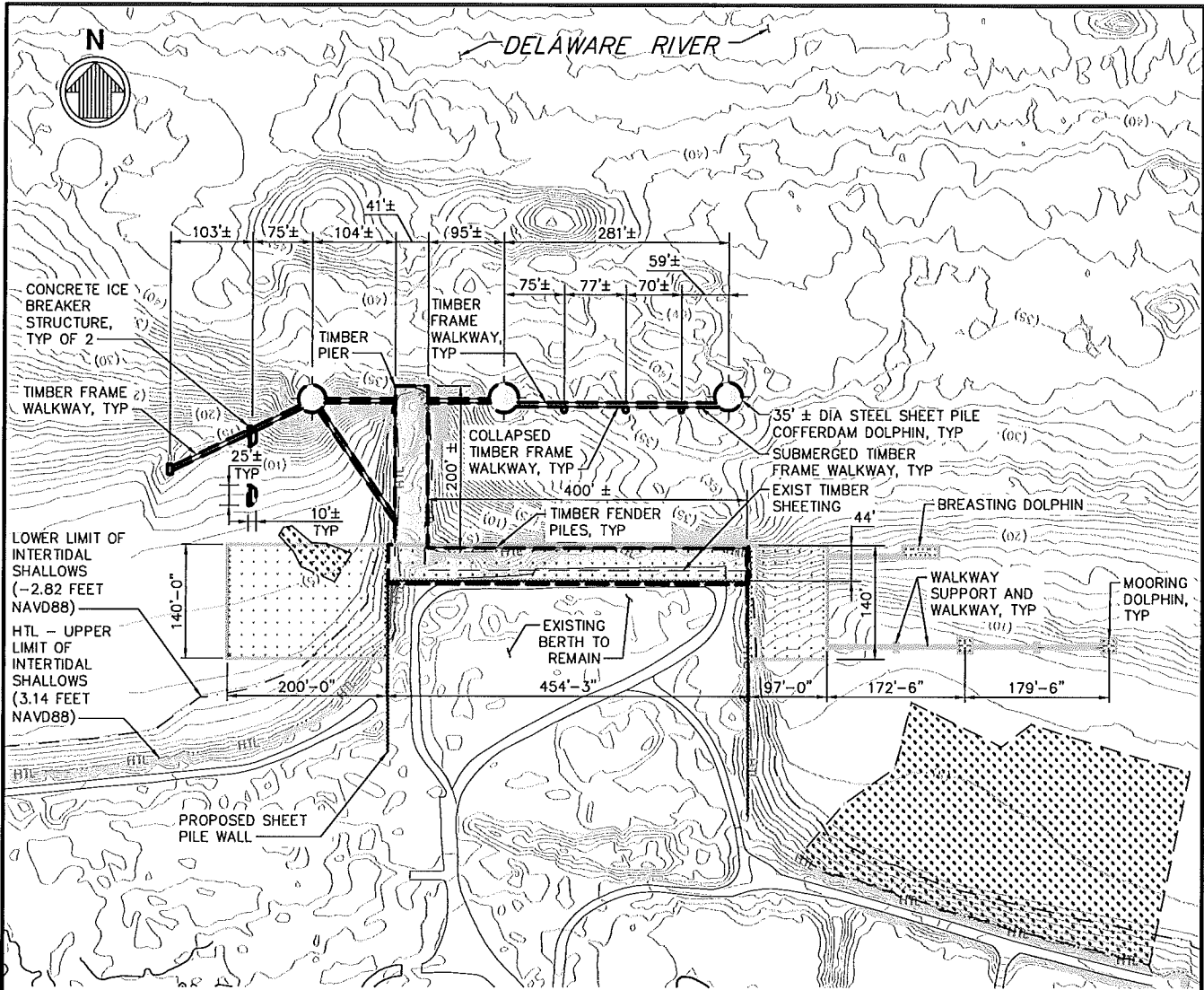

DATE: AUGUST 18, 2016  
 REISSUED: JANUARY 3, 2017  
 SHEET 05 OF 31



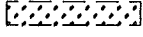

**PLAN – DEMOLITION AND NEW MARINE STRUCTURES**

**LEGEND**

-  EXISTING BERTH STRUCTURE TO BE DEMOLISHED
-  PROPOSED PILE SUPPORTED STRUCTURES
-  SUBMERGED AQUATIC VEGETATION
-  NEW FILL IN STATE OPEN WATERS

**NOTES:**

1. STEEL SHEET PILE STRUCTURES AND CONCRETE ICE BREAKER STRUCTURES SHALL BE FULLY EXTRACTED.
2. NO NET FILL PROPOSED.
3. REFER TO SHEET 09 FOR IMPACTS TO SAV.

APPLICATION BY:  
 DELAWARE RIVER PARTNERS, LLC  
 1345 AVENUE OF THE AMERICAS  
 46TH FLOOR  
 NEW YORK, NEW YORK 10105

ENGINEER:  
 **moffatt & nichol**

DRP GIBBSTOWN  
 LOGISTICS CENTER

PROJECT LOCATION:  
 DELAWARE RIVER  
 GIBBSTOWN, GREENWICH TOWNSHIP, NEW JERSEY

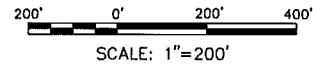

DATE: AUGUST 18, 2016  
 REISSUED: JANUARY 3, 2017

SHEET 06A OF 31

MATCH LINE - SEE PLAN B - CURRENT CONDITION



PLAN A - CURRENT CONDITION

APPLICATION BY:  
 DELAWARE RIVER PARTNERS, LLC  
 1345 AVENUE OF THE AMERICAS  
 46TH FLOOR  
 NEW YORK, NEW YORK 10105

ENGINEER:



DRP GIBBSTOWN  
 LOGISTICS CENTER

PROJECT LOCATION:  
 DELAWARE RIVER  
 GIBBSTOWN, GREENWICH TOWNSHIP, NEW JERSEY

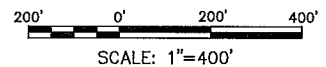

DATE: JANUARY 25, 2017

SHEET: PN-1 OF 13

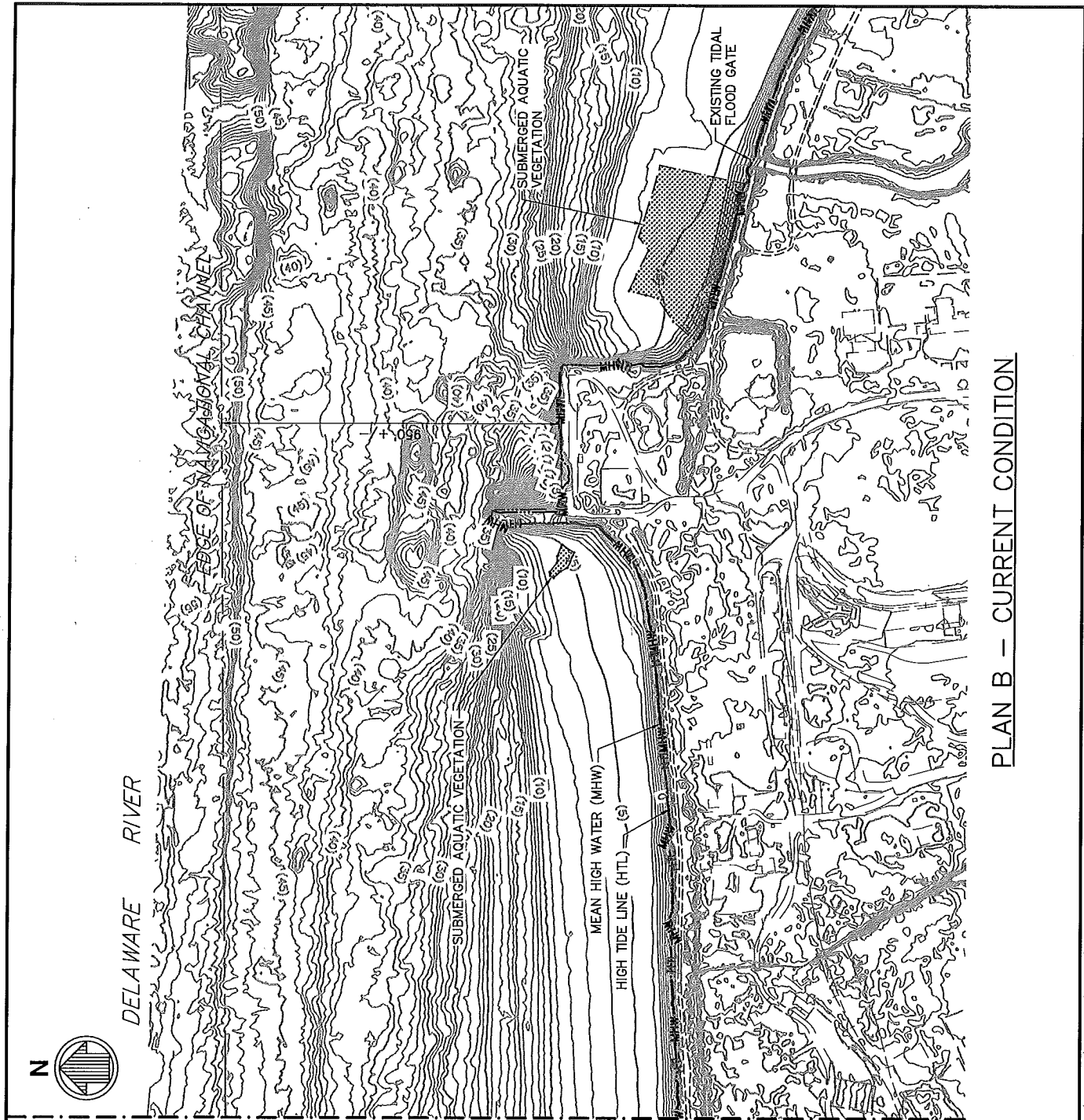

PLAN B - CURRENT CONDITION

APPLICATION BY:  
 DELAWARE RIVER PARTNERS, LLC  
 1345 AVENUE OF THE AMERICAS  
 46TH FLOOR  
 NEW YORK, NEW YORK 10105

ENGINEER:  
 **moffatt & nichol**

DRP GIBBSTOWN  
 LOGISTICS CENTER

PROJECT LOCATION:  
 DELAWARE RIVER  
 GIBBSTOWN, GREENWICH TOWNSHIP, NEW JERSEY

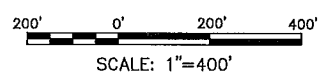

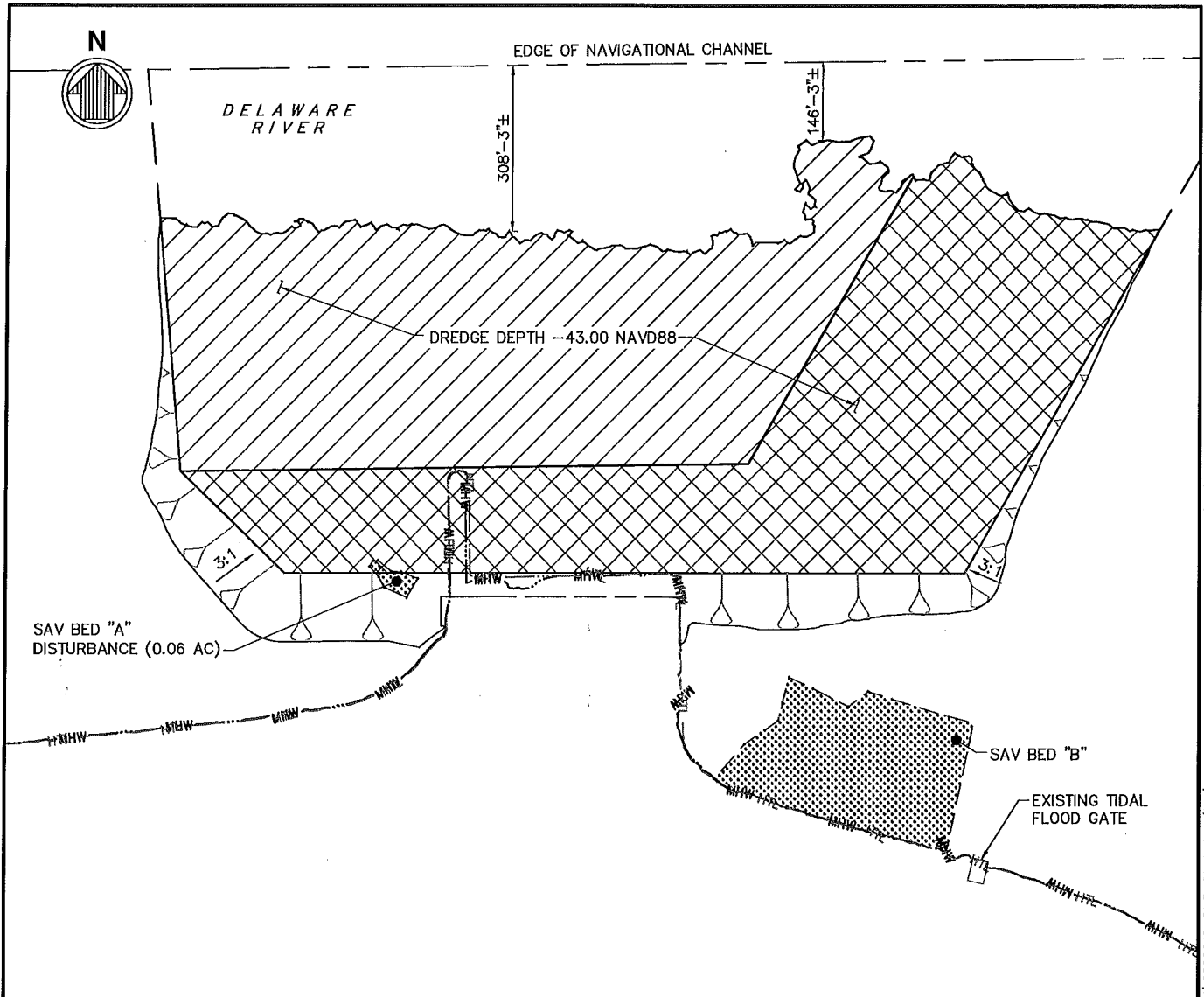

DATE: JANUARY 25, 2017

SHEET: PN-2 OF 13



**PLAN - DREDGING**

**LEGEND**

-  NEW DREDGING AREA (12.40 AC)
-  MAINTENANCE DREDGING AREA (12.78 AC)
-  SUBMERGED AQUATIC VEGETATION

**NOTES:**

1. DREDGING AREAS MEASURED TO TOE OF SLOPE.
2. IMPACT AREAS MEASURED TO TOP OF SLOPE.

APPLICATION BY:  
 DELAWARE RIVER PARTNERS, LLC  
 1345 AVENUE OF THE AMERICAS  
 46TH FLOOR  
 NEW YORK, NEW YORK 10105

ENGINEER:  
 **moffatt & nichol**

DRP GIBBSTOWN  
 LOGISTICS CENTER

PROJECT LOCATION:  
 DELAWARE RIVER  
 GIBBSTOWN, GREENWICH TOWNSHIP, NEW JERSEY

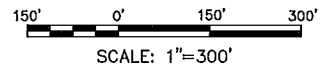

DATE: JANUARY 25, 2017

SHEET: PN-3 OF 13

MATCH LINE - SEE PLAN B - GENERAL ARRANGEMENT PROPOSED STRUCTURES

DELAWARE RIVER

PROPOSED OUTFALL STRUCTURE

PLAN A - GENERAL ARRANGEMENT PROPOSED STRUCTURES



APPLICATION BY:  
DELAWARE RIVER PARTNERS, LLC  
1345 AVENUE OF THE AMERICAS  
46TH FLOOR  
NEW YORK, NEW YORK 10105

ENGINEER:



DRP GIBBSTOWN  
LOGISTICS CENTER

PROJECT LOCATION:  
DELAWARE RIVER  
GIBBSTOWN, GREENWICH TOWNSHIP, NEW JERSEY

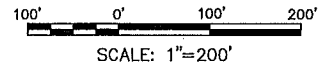

DATE: JANUARY 25, 2017

SHEET: PN-4 OF 13

MATCH LINE — SEE PLAN C — GENERAL  
ARRANGEMENT PROPOSED STRUCTURES

DELAWARE RIVER

PROPOSED OUTFALL STRUCTURE

PLAN B — GENERAL ARRANGEMENT PROPOSED STRUCTURES



MATCH LINE — SEE PLAN A — GENERAL  
ARRANGEMENT PROPOSED STRUCTURES

APPLICATION BY:  
DELAWARE RIVER PARTNERS, LLC  
1345 AVENUE OF THE AMERICAS  
46TH FLOOR  
NEW YORK, NEW YORK 10105

ENGINEER:



DRP GIBBSTOWN  
LOGISTICS CENTER

PROJECT LOCATION:  
DELAWARE RIVER  
GIBBSTOWN, GREENWICH TOWNSHIP, NEW JERSEY

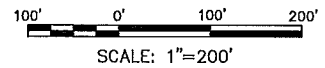

DATE: JANUARY 25, 2017

SHEET: PN-5 OF 13



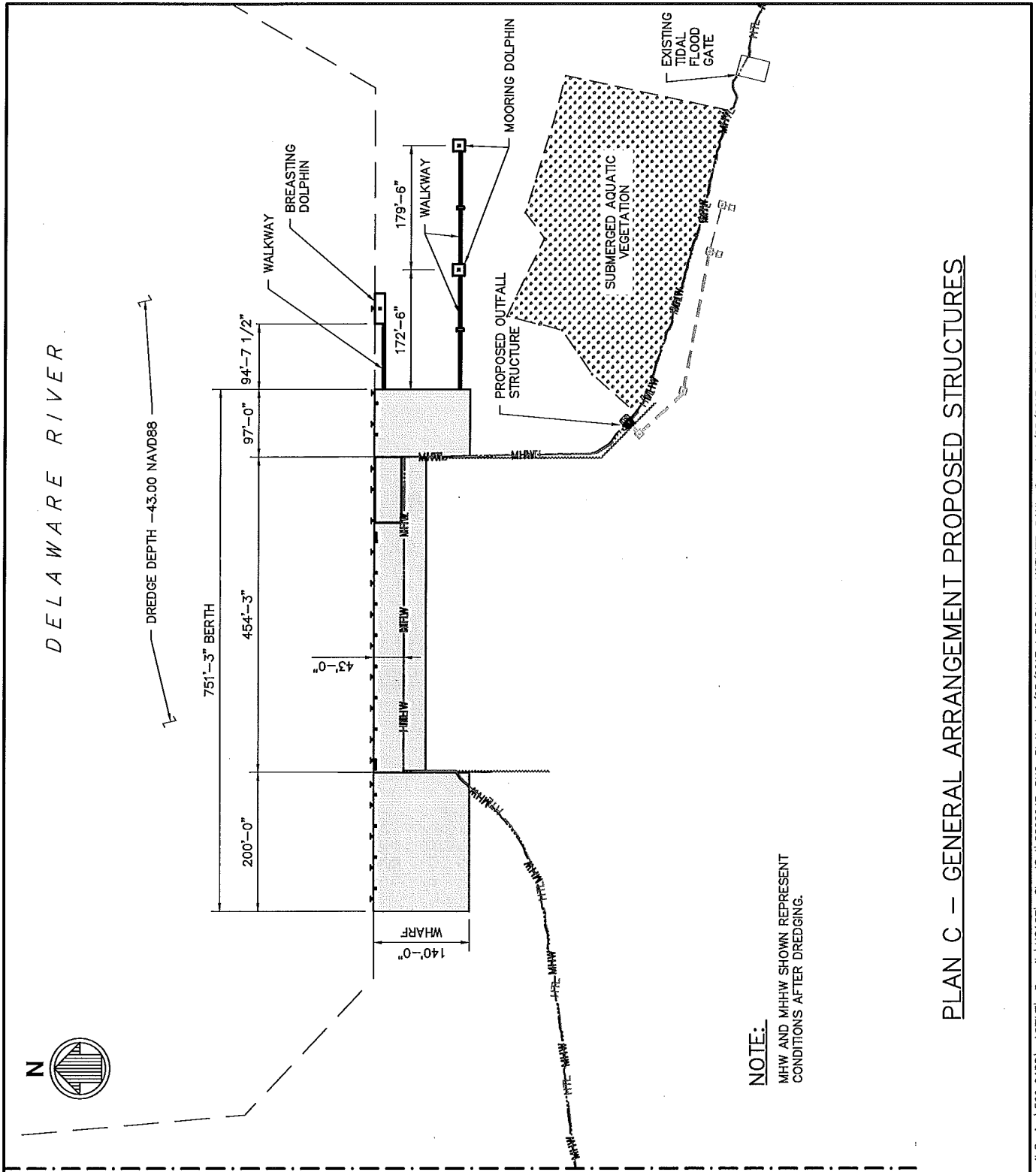

DELAWARE RIVER

DREDGE DEPTH -43.00 NAVD88

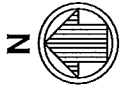

**NOTE:**  
MHW AND MHHW SHOWN REPRESENT  
CONDITIONS AFTER DREDGING.

MATCH LINE - SEE PLAN B - GENERAL ARRANGEMENT PROPOSED STRUCTURES

PLAN C - GENERAL ARRANGEMENT PROPOSED STRUCTURES

APPLICATION BY:  
DELAWARE RIVER PARTNERS, LLC  
1345 AVENUE OF THE AMERICAS  
46TH FLOOR  
NEW YORK, NEW YORK 10105

ENGINEER:  
 **moffatt & nichol**

DRP GIBBSTOWN  
LOGISTICS CENTER

PROJECT LOCATION:  
DELAWARE RIVER  
GIBBSTOWN, GREENWICH TOWNSHIP, NEW JERSEY

100' 0' 100' 200'  
SCALE: 1"=200'

DATE: JANUARY 25, 2017

SHEET: PN-6 OF 13

File: G:\BA\8866 Repairs\8866-04 Permit Design\500 CAD\ACTIVE\Permits\USACE\SheetSet\886604P-PN6; Plotted: 1/25/2017 4:36 PM by VOELKER, PAUL; Saved: 1/25/2017 4:34 PM by PVOELKER



DELAWARE RIVER

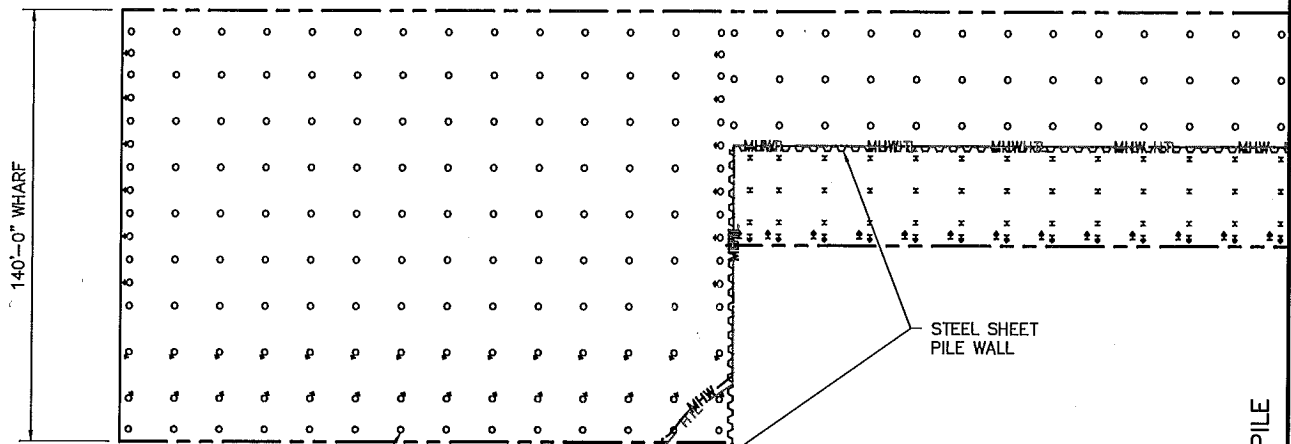

24" Ø STEEL PIPE PILE, TYP

STEEL SHEET PILE WALL

MATCH LINE - SEE PLAN B - PILE

**NOTE:**  
MHW AND MHHW SHOWN REPRESENT  
CONDITIONS AFTER DREDGING.

PLAN A - PILE

APPLICATION BY:  
DELAWARE RIVER PARTNERS, LLC  
1345 AVENUE OF THE AMERICAS  
46TH FLOOR  
NEW YORK, NEW YORK 10105

ENGINEER:  
 **moffatt & nichol**

DRP GIBBSTOWN  
LOGISTICS CENTER

PROJECT LOCATION:  
DELAWARE RIVER  
GIBBSTOWN, GREENWICH TOWNSHIP, NEW JERSEY

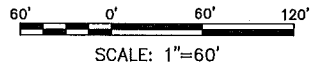

DATE: JANUARY 25, 2017

SHEET: PN-7 OF 13

File: c:\BA\8866 Rep\pno\8866-04 Permit Design\500 CAD\ACTIVE\Permits\USACE\SheetSet\886604P-PN7; Plotted: 1/25/2017 4:36 PM by VOELKER, PAUL; Saved: 1/25/2017 9:16 AM by MMLRINSON



DELAWARE RIVER

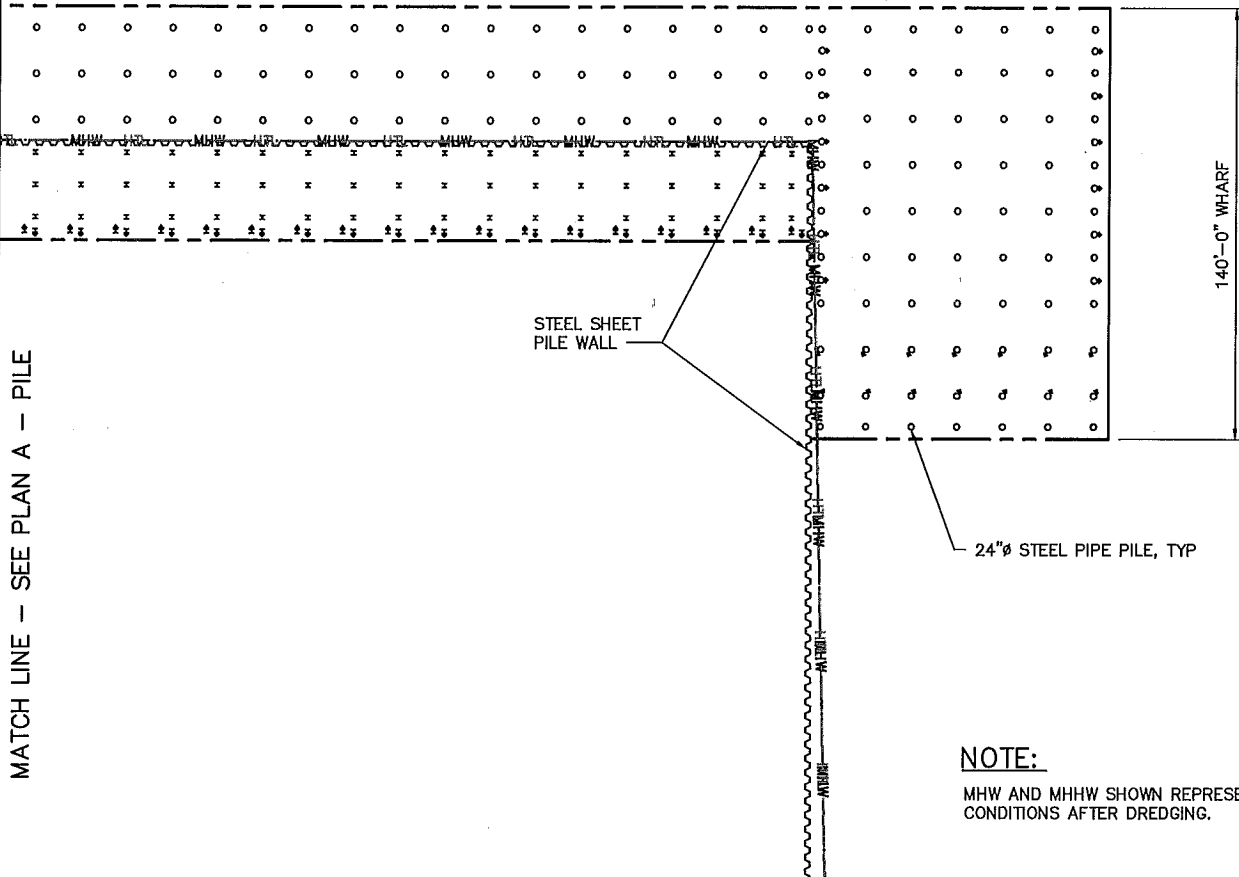

PLAN B - PILE

APPLICATION BY:  
 DELAWARE RIVER PARTNERS, LLC  
 1345 AVENUE OF THE AMERICAS  
 46TH FLOOR  
 NEW YORK, NEW YORK 10105

ENGINEER:



DRP GIBBSTOWN  
 LOGISTICS CENTER

PROJECT LOCATION:  
 DELAWARE RIVER  
 GIBBSTOWN, GREENWICH TOWNSHIP, NEW JERSEY

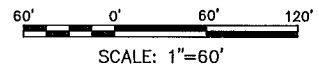

DATE: JANUARY 25, 2017

SHEET: PN-8 OF 13



DELAWARE RIVER

CONCRETE TOPPING SLAB OVER  
PRECAST CONCRETE PANEL, TYP

140'-0" WHARF

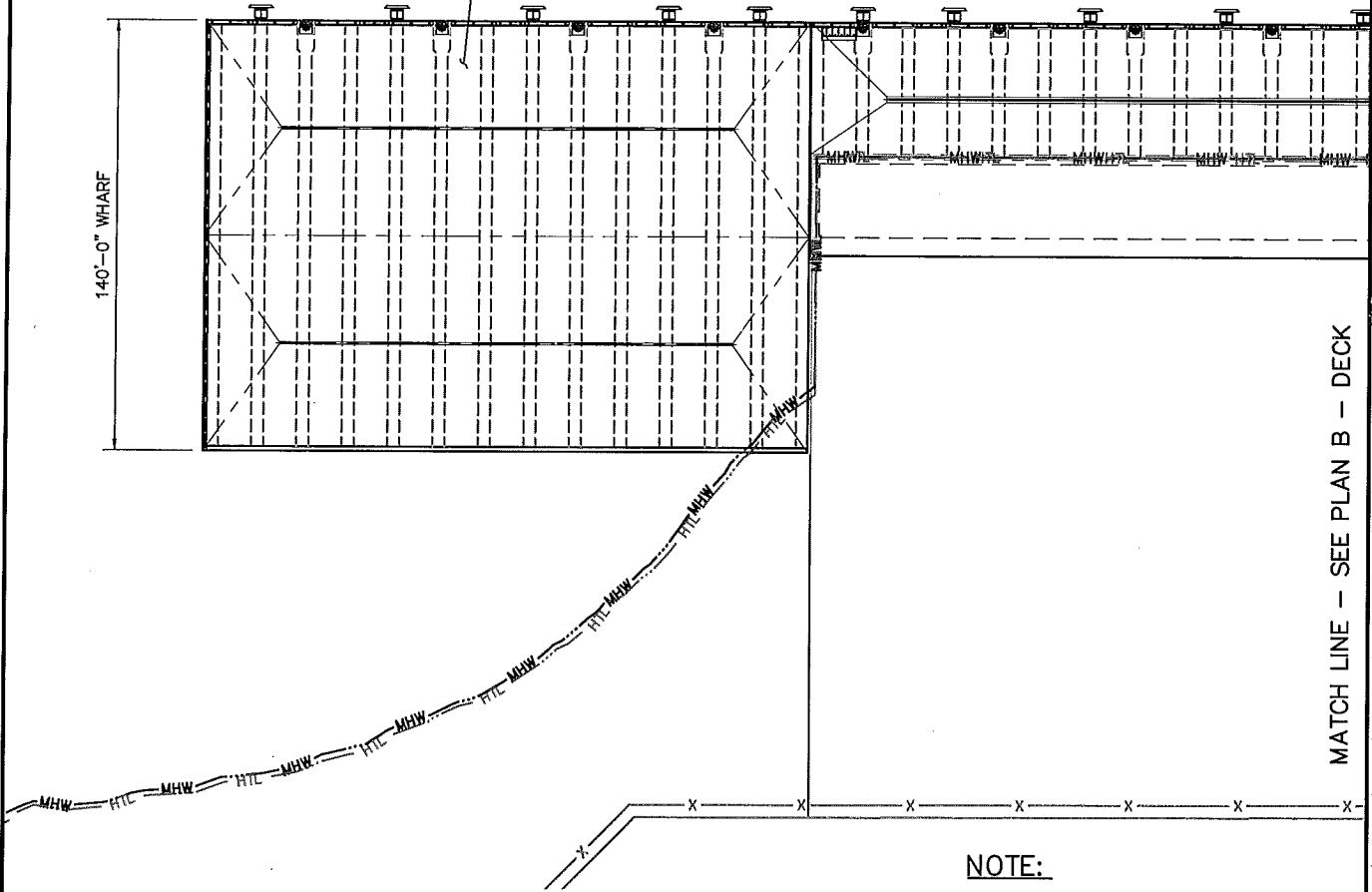

MATCH LINE -- SEE PLAN B -- DECK

NOTE:

MHW AND MHL SHOWN REPRESENT  
CONDITIONS AFTER DREDGING.

PLAN A -- DECK

APPLICATION BY:  
DELAWARE RIVER PARTNERS, LLC  
1345 AVENUE OF THE AMERICAS  
46TH FLOOR  
NEW YORK, NEW YORK 10105

ENGINEER:



DRP GIBBSTOWN  
LOGISTICS CENTER

PROJECT LOCATION:  
DELAWARE RIVER  
GIBBSTOWN, GREENWICH TOWNSHIP, NEW JERSEY

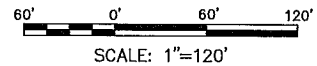

DATE: JANUARY 25, 2017

SHEET: PN-9 OF 13

File: c:\BA\8866 Repair\8866-04 Permit Design\500 CADD\ACTIVE\Permit Design\886604P-PNG; Plotted: 1/25/2017 4:36 PM by VOELKER, PAUL; Saved: 1/25/2017 9:21 AM by MMLKINSON



DELAWARE RIVER

CONCRETE TOPPING SLAB OVER  
PRECAST CONCRETE PANEL, TYP

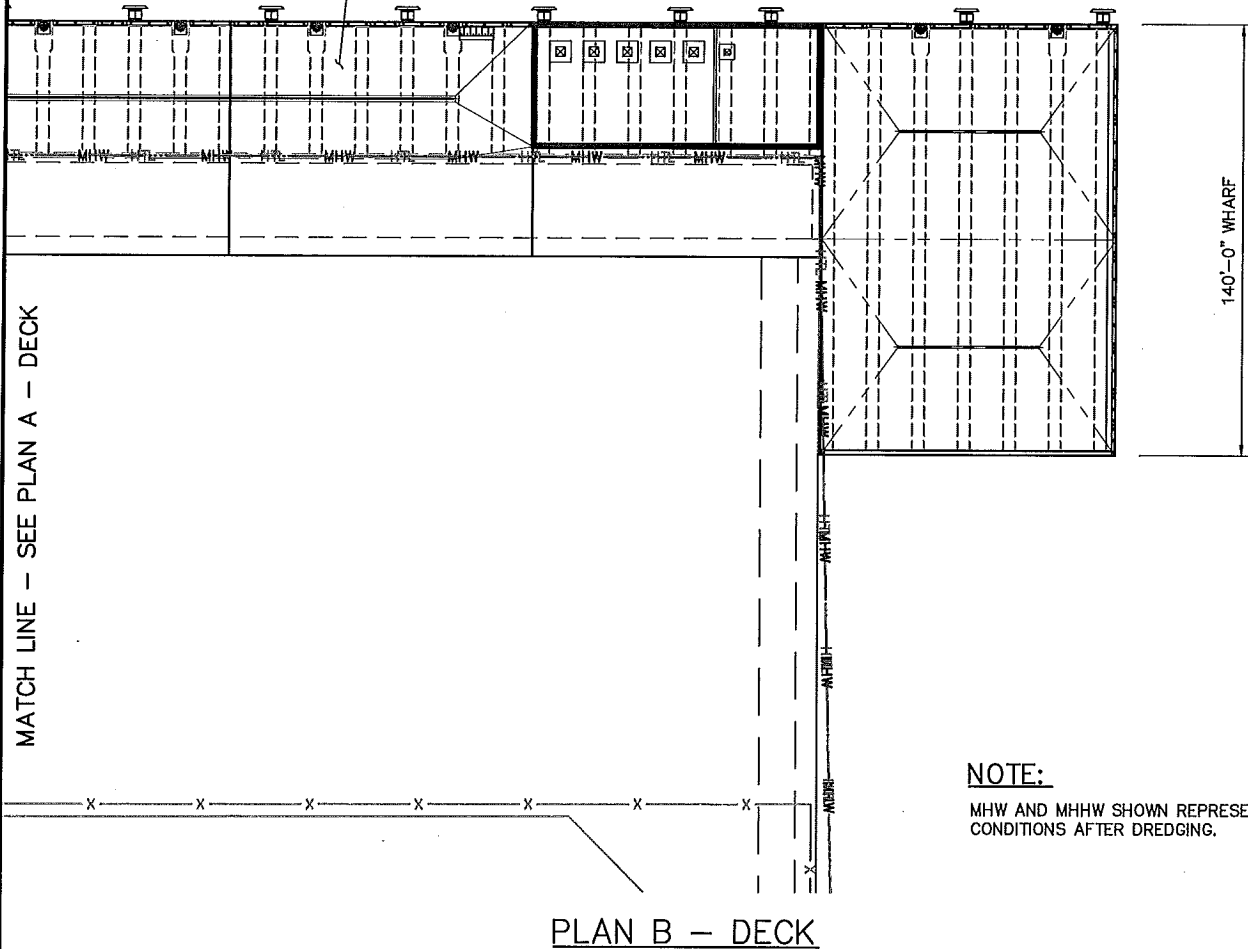

APPLICATION BY:  
DELAWARE RIVER PARTNERS, LLC  
1345 AVENUE OF THE AMERICAS  
46TH FLOOR  
NEW YORK, NEW YORK 10105

ENGINEER:



DRP GIBBSTOWN  
LOGISTICS CENTER

PROJECT LOCATION:  
DELAWARE RIVER  
GIBBSTOWN, GREENWICH TOWNSHIP, NEW JERSEY

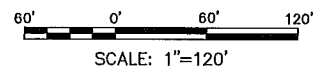

DATE: JANUARY 25, 2017

SHEET: PN-10 OF 13



DELAWARE RIVER

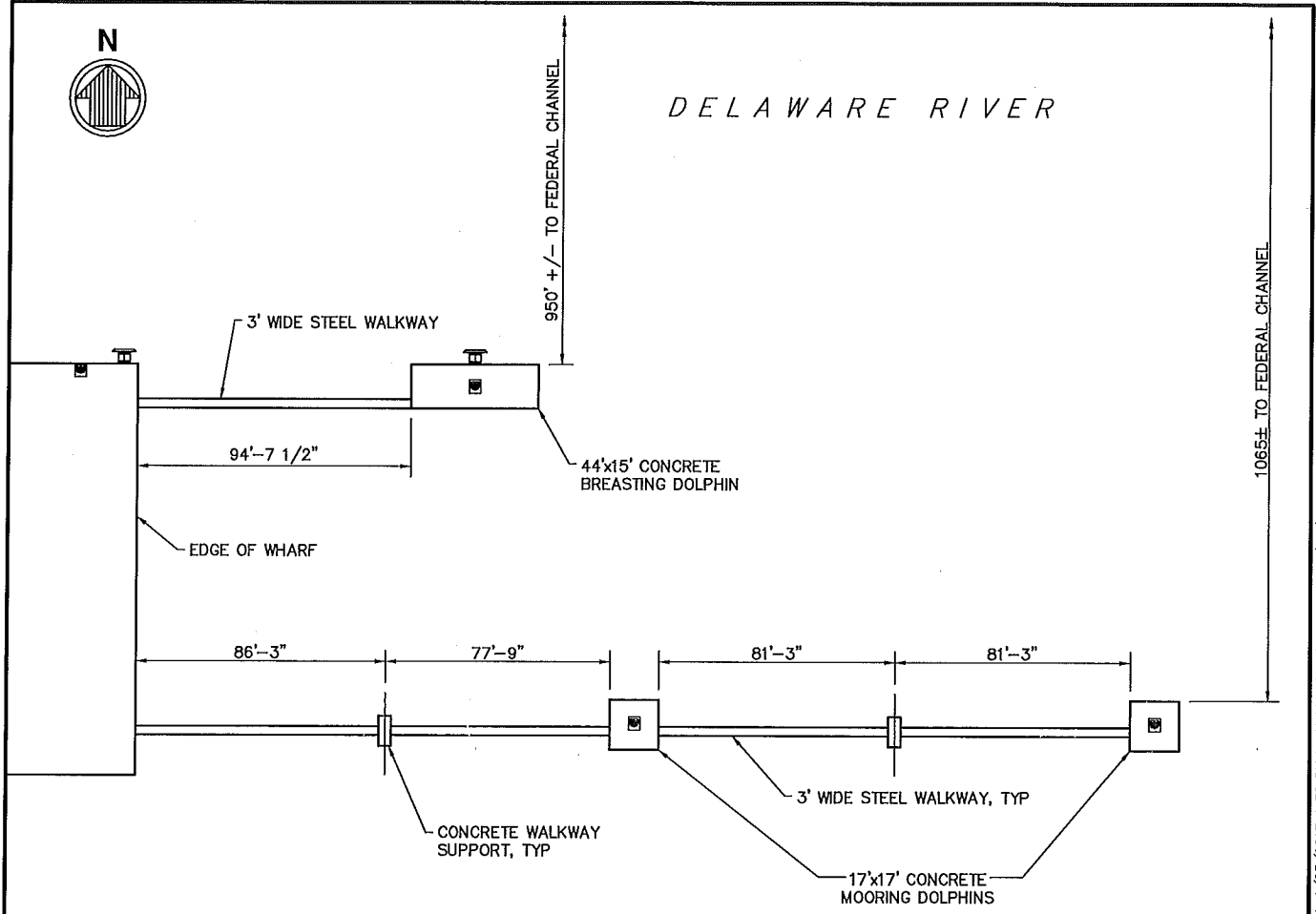

**NOTE:**

MHW AND MHH SHOWN REPRESENT CONDITIONS AFTER DREDGING.

**PLAN – BREASTING AND MOORING DOLPHINS**

APPLICATION BY:  
DELAWARE RIVER PARTNERS, LLC  
1345 AVENUE OF THE AMERICAS  
46TH FLOOR  
NEW YORK, NEW YORK 10105

ENGINEER:



DRP GIBBSTOWN  
LOGISTICS CENTER

PROJECT LOCATION:  
DELAWARE RIVER  
GIBBSTOWN, GREENWICH TOWNSHIP, NEW JERSEY

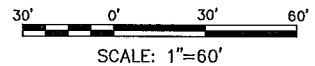

DATE: JANUARY 25, 2017

SHEET: PN-11 OF 13



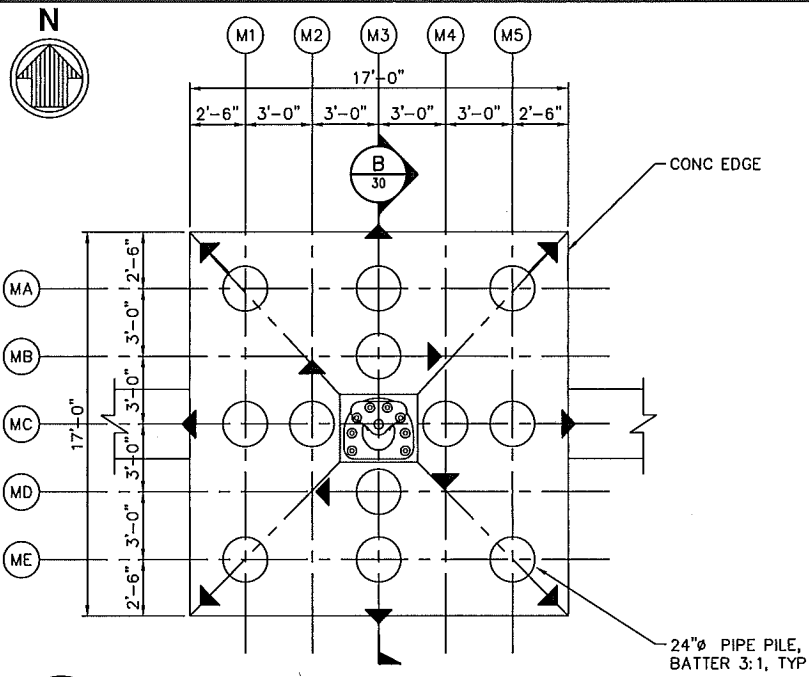

**A** TOP PLAN – TYPICAL MOORING DOLPHIN  
 27 SCALE: 1/8" = 1'-0"

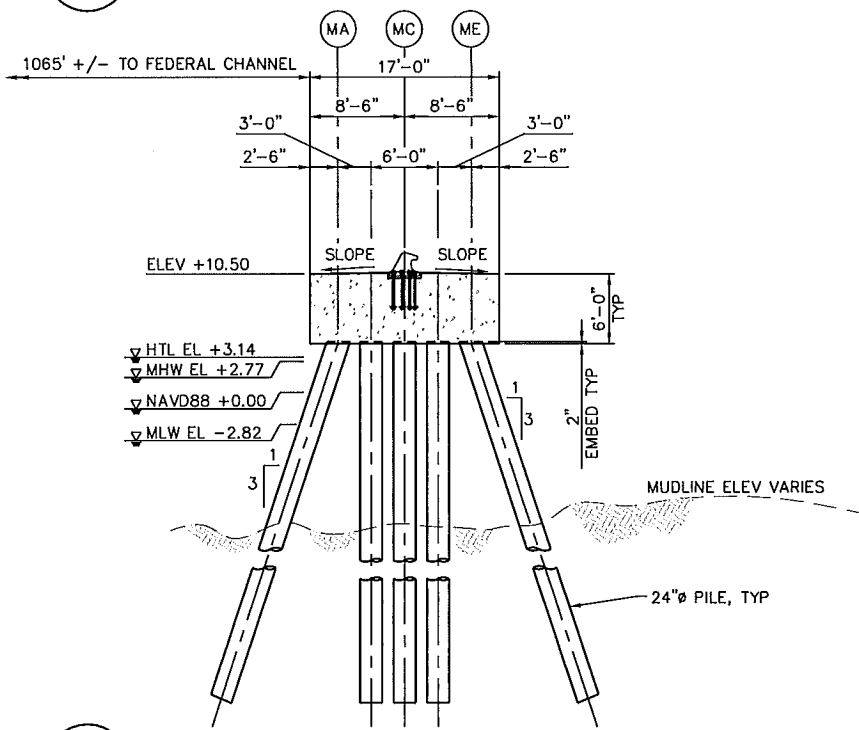

**B** SECTION – TYPICAL MOORING DOLPHIN  
 30 SCALE: 1/16" = 1'-0"

APPLICATION BY:  
 DELAWARE RIVER PARTNERS, LLC  
 1345 AVENUE OF THE AMERICAS  
 46TH FLOOR  
 NEW YORK, NEW YORK 10105

ENGINEER:  
 **moffatt & nichol**

DRP GIBBSTOWN  
 LOGISTICS CENTER

PROJECT LOCATION:  
 DELAWARE RIVER  
 GIBBSTOWN, GREENWICH TOWNSHIP, NEW JERSEY

16' 0' 16' 32'  
 SCALE: 1/16"=1'  
 8' 0' 8' 16'  
 SCALE: 1/8"=1'

DATE: AUGUST 18, 2016  
 REISSUED: JANUARY 3, 2017

SHEET 30 OF 31

File: Q:\BA\8866 Repaura\8866-04 Permit Design\500 CAD\ACTIVE\ACTIVE\Permits\USA\ACE\Sheet\886604P-030.dwg Plotted: 12/29/2016 9:57 AM by WILKINSON, MELISSA. Saved: 12/23/2016 3:34 PM by WILKINSON

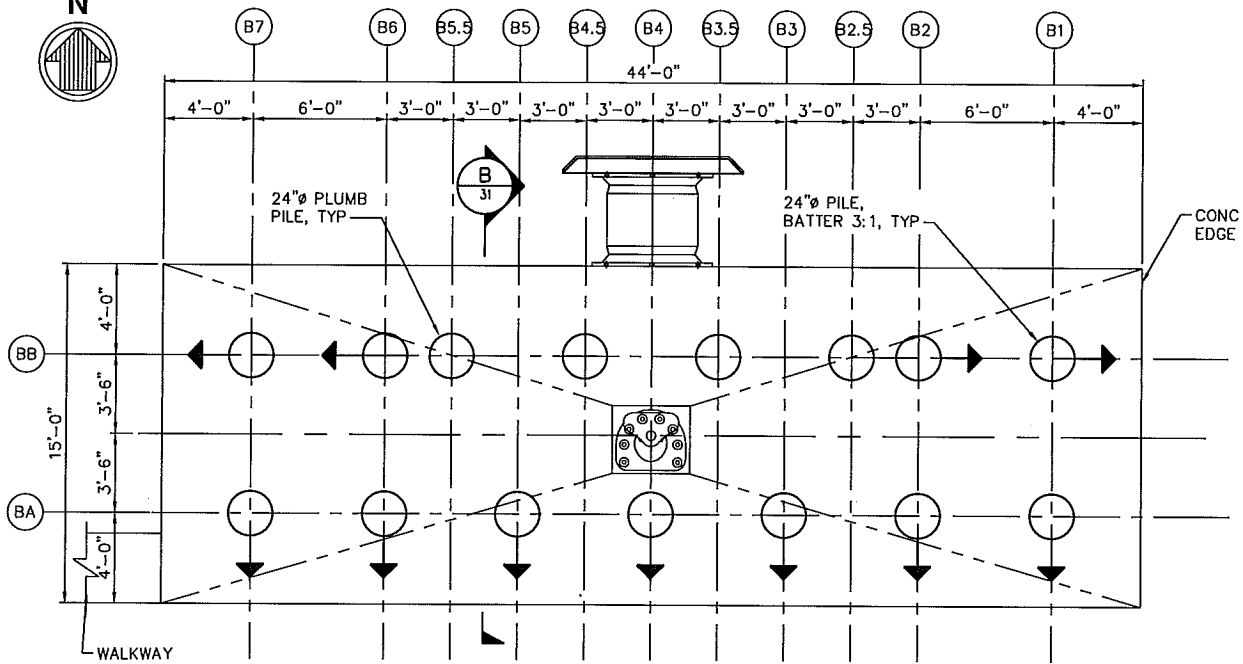

**A** TOP PLAN – TYPICAL BREASTING DOLPHIN  
 27 SCALE: 1/8" = 1'-0"

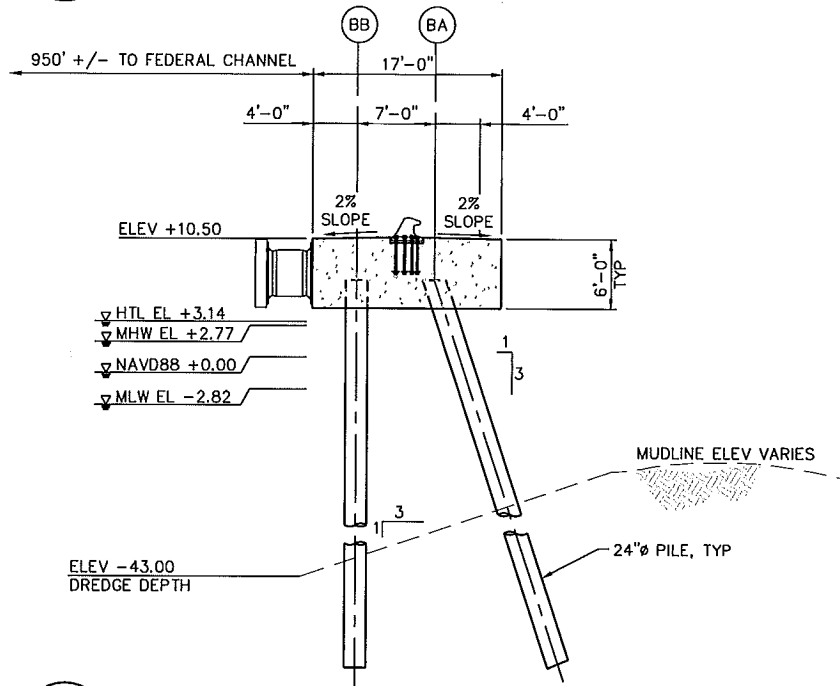

**B** SECTION – TYPICAL BREASTING DOLPHIN  
 31 SCALE: 1/16" = 1'-0"

APPLICATION BY:  
 DELAWARE RIVER PARTNERS, LLC  
 1345 AVENUE OF THE AMERICAS  
 46TH FLOOR  
 NEW YORK, NEW YORK 10105

ENGINEER:



DRP GIBBSTOWN  
 LOGISTICS CENTER

PROJECT LOCATION:  
 DELAWARE RIVER  
 GIBBSTOWN, GREENWICH TOWNSHIP, NEW JERSEY

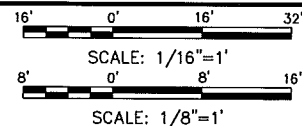

DATE: AUGUST 18, 2016  
 REISSUED: JANUARY 3, 2017

SHEET 31 OF 31

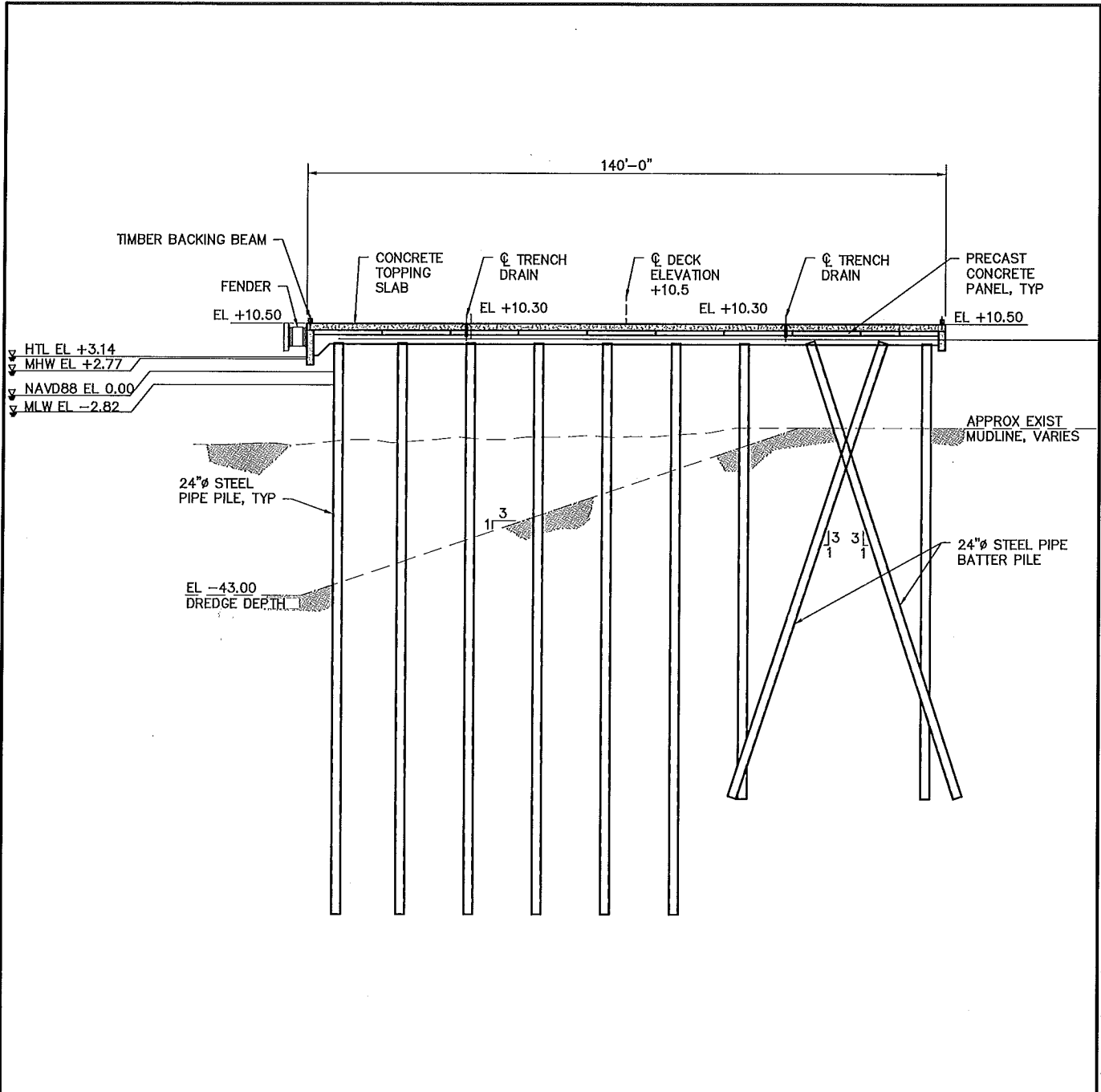

TYPICAL SECTION – OPEN WHARF

APPLICATION BY:  
 DELAWARE RIVER PARTNERS, LLC  
 1345 AVENUE OF THE AMERICAS  
 46TH FLOOR  
 NEW YORK, NEW YORK 10105

ENGINEER:  
 **moffatt & nichol**

DRP GIBBSTOWN  
 LOGISTICS CENTER

PROJECT LOCATION:  
 DELAWARE RIVER  
 GIBBSTOWN, GREENWICH TOWNSHIP, NEW JERSEY

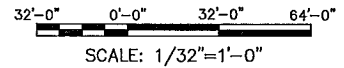

DATE: JANUARY 25, 2017

SHEET: PN-12 OF 13

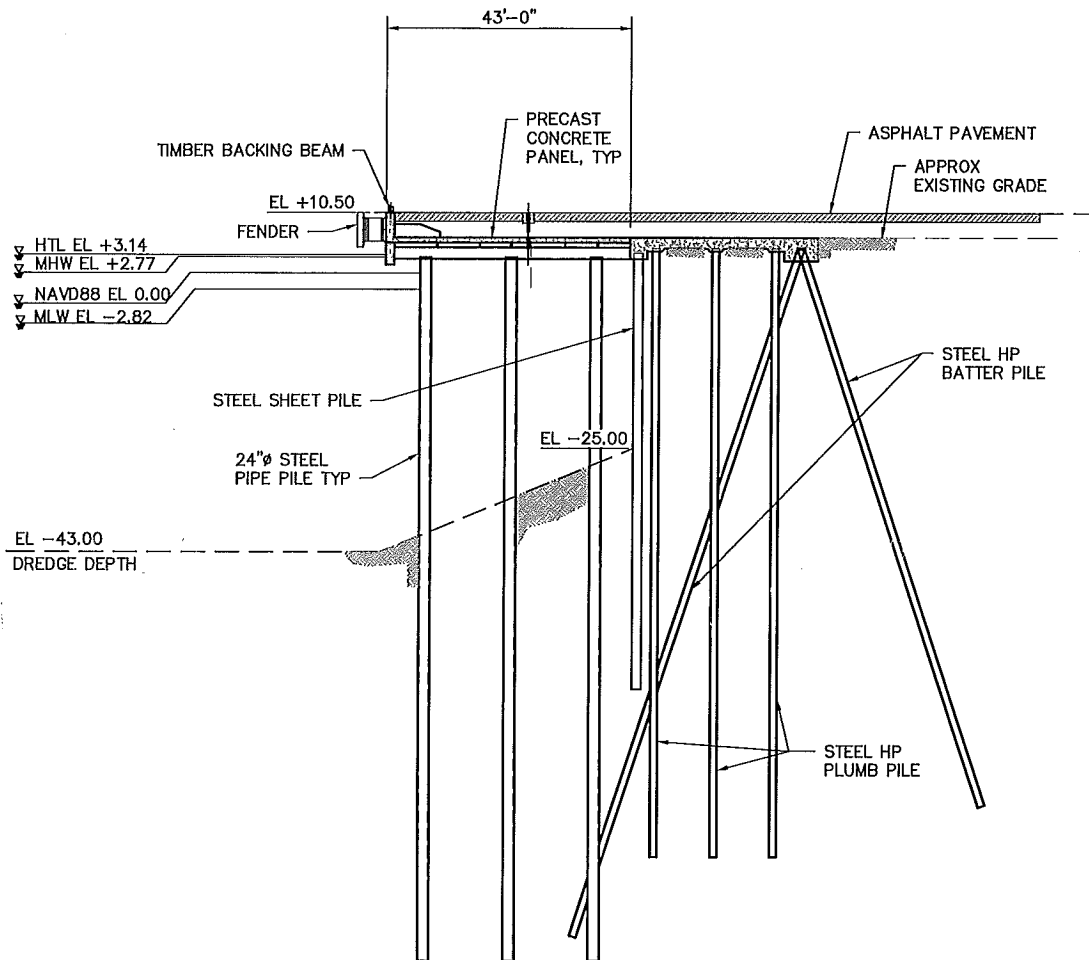

TYPICAL SECTION – OPEN WHARF WITH CUT OFF WALL

APPLICATION BY:  
 DELAWARE RIVER PARTNERS, LLC  
 1345 AVENUE OF THE AMERICAS  
 46TH FLOOR  
 NEW YORK, NEW YORK 10105

ENGINEER:



DRP GIBBSTOWN  
 LOGISTICS CENTER

PROJECT LOCATION:  
 DELAWARE RIVER  
 GIBBSTOWN, GREENWICH TOWNSHIP, NEW JERSEY

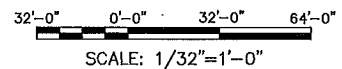

DATE: JANUARY 25, 2017

SHEET: PN-13 OF 13

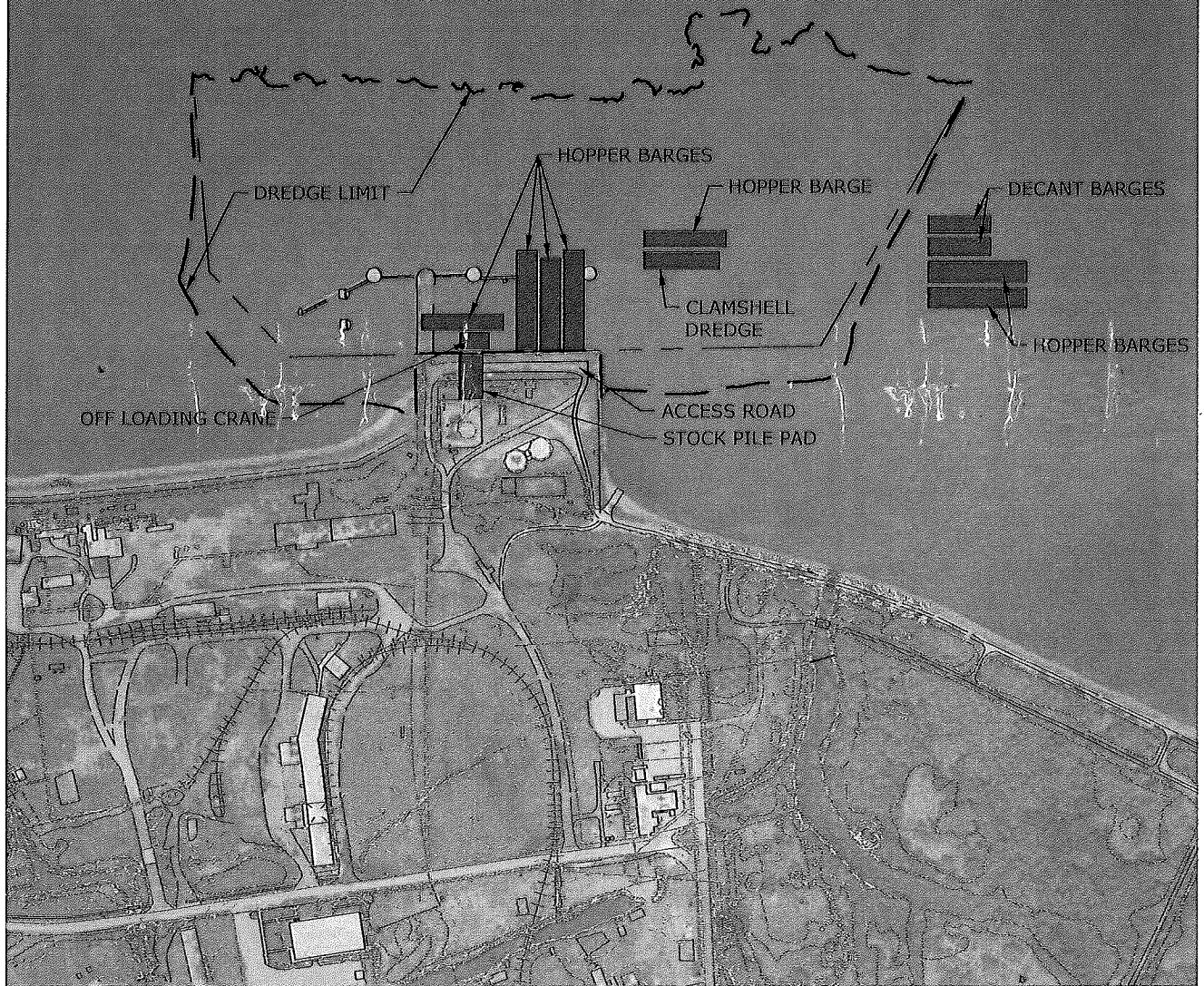
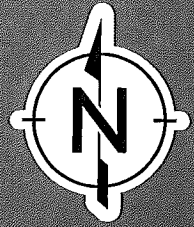

BKLEIN 2/15/17 F:\0235702\_REPAUNO\_DESIGN\PDW SAMPLING < DREDGEEQUIP\_0235702 >

SOURCE:  
AERIAL IMAGERY: Google™ earth 5/24/2016

0 400  
SCALE IN FEET

**RAMBOLL** ENVIRON

### PROPOSED DREDGING OPERATIONS

DRP GIBBSTOWN LOGISTICS CENTER  
GIBBSTOWN, NEW JERSEY

FIGURE

**1**

DRAFTED BY: BK

DATE: 2/15/2017

PROJECT: 0235702A

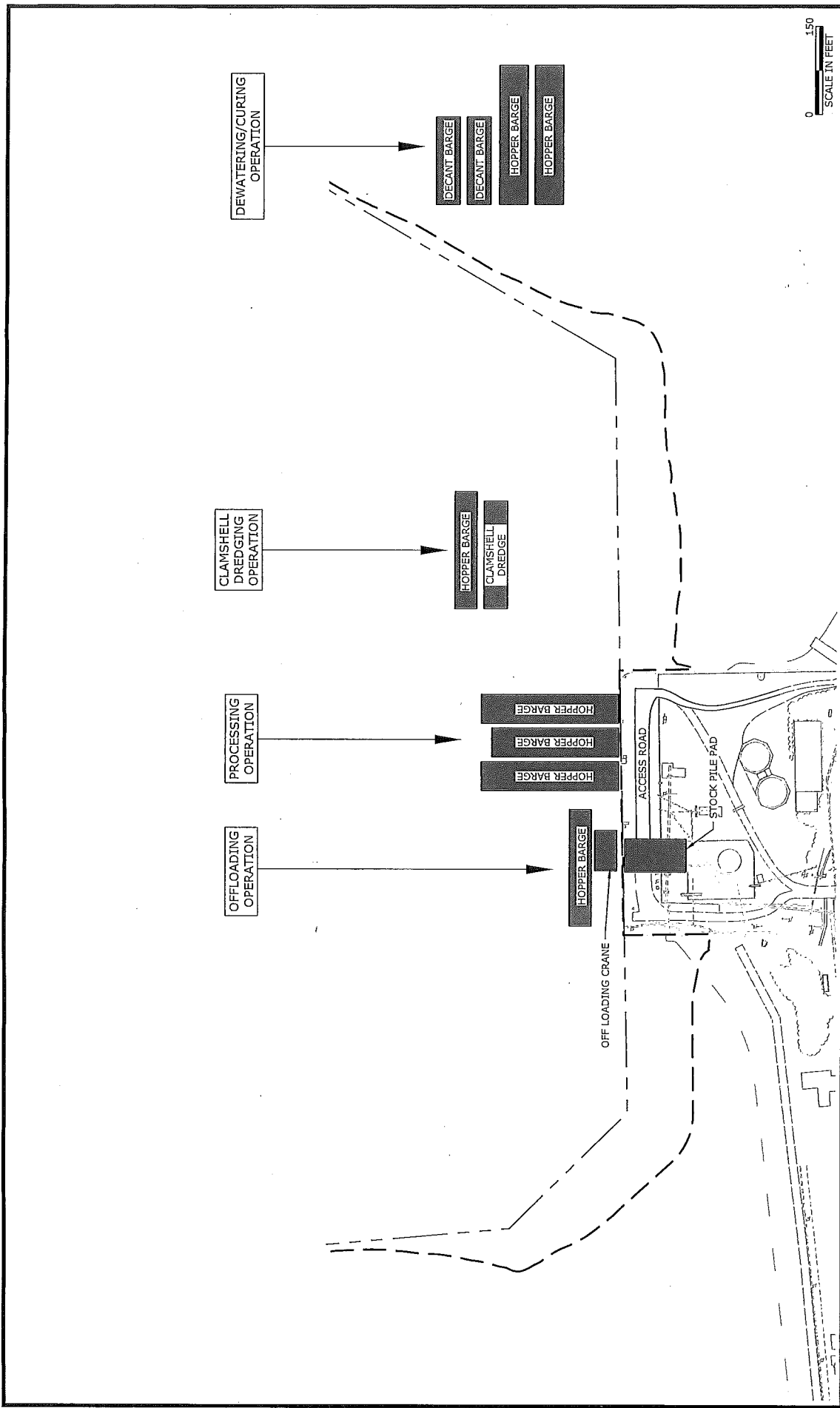

	<b>DREDGING EQUIPMENT LAYOUT</b> DUPONT REPAUNO SITE GIBBSTOWN, NEW JERSEY	
	DRAFTED BY: BK	DATE: 12/09/2016

FIGURE  
**2**  
PROJECT: 035702



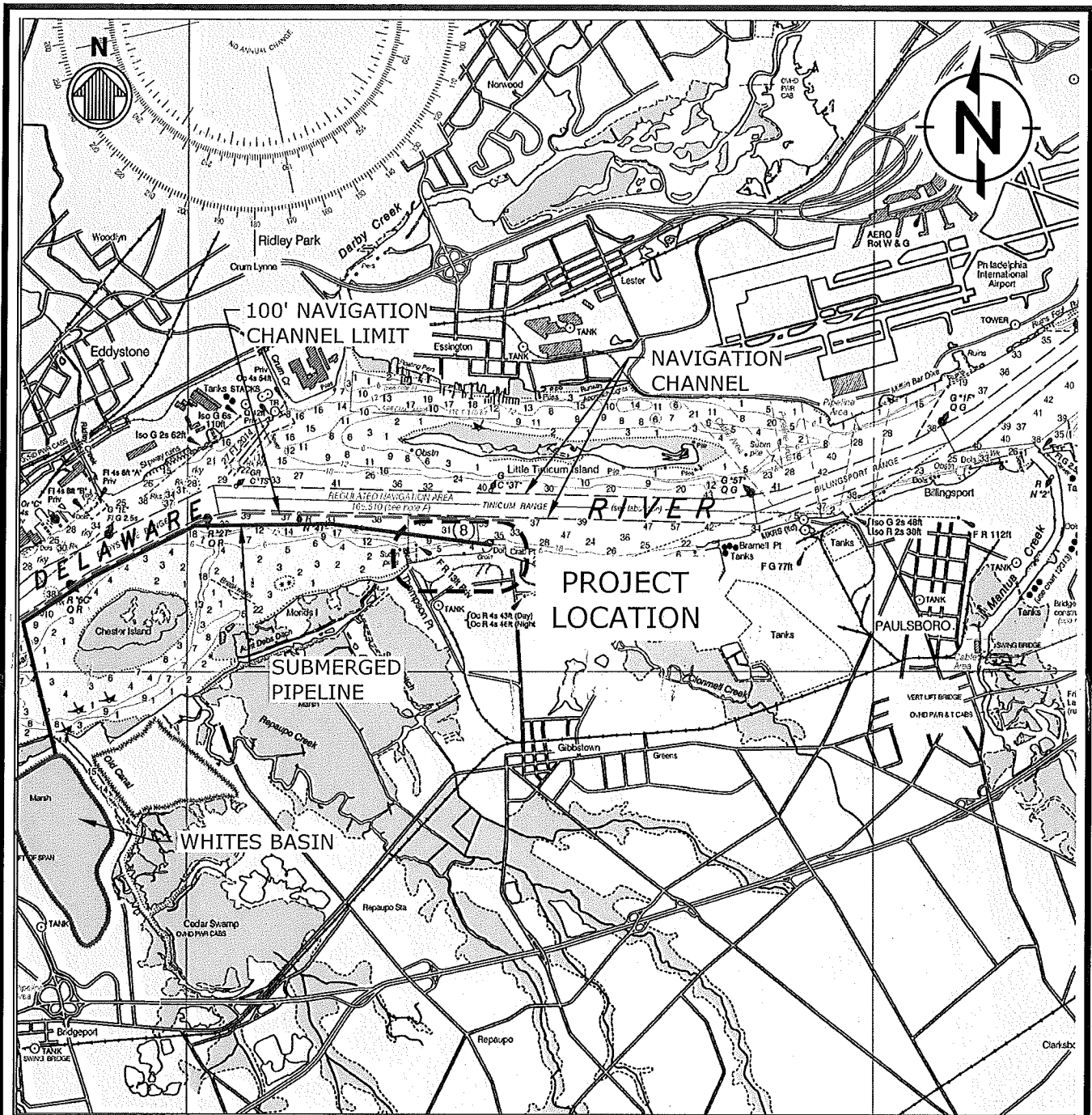

SOURCE:  
NOAA CHART 12312, 56TH ED., MAY 2012



SKLEIN 2/15/17 F:\0235702\_REPAUNO\_DESIGN\_PDM\_SAMPLING < DREDGING LAYOUT >

**RAMBOLL** ENVIRON

**LAYOUT OF PROPOSED  
HYDRAULIC DREDGING PIPELINE  
DRP GIBBSTOWN LOGISTIC CENTER  
GIBBSTOWN, NEW JERSEY**

**FIGURE  
2**

DRAFTED BY: BK

DATE: 02/15/2017

PROJECT: 0235702A